

RT

Random Thoughts

A Selection of Articles:
The 2010 Sampler



By
 For **Modellers**

The quarterly journal of the
 International Plastic Modellers Society of Canada www.ipmscanada.com



In This Special Edition

- ◆ 1/72 CF-101 Voodoo
- ◆ 1/35 Cdn Army Sherman, Italy 1944
- ◆ Oddball RCN Sea Fury Schemes
- ◆ 1/72 Boeing 40B-4
- ◆ 1/48 Kawanishi N1K1 Kyofu 'Rex'
- ◆ Cdn Army 1/35 Centurion Mk.V
- ◆ 1/400 HMCS Bonaventure
- ◆ That's it, that's all - enjoy the issue!



The 2010 Sampler

The International Plastic Modellers Society of Canada

www.ipmscanada.com



Foreword

Welcome! You're looking a special 'Sampler' edition of **RT** – Random Thoughts, the official journal of IPMS Canada. The idea for this came first about as a way of introducing, or re-introducing modellers to IPMS Canada, while members of the IPMS Canada National Executive attended the IPMS/USA 2009 National Convention in Columbus, Ohio. This is the 2010 edition, created for distribution after the 2010 Nats in Phoenix, Arizona.

This is a screen-resolution PDF file, which means it should look very nice on your computer monitor, but the imagery will look somewhat degraded if printed out on paper. Rest assured that **RT** is printed on high-quality stock, with imagery and graphics rendered at 300 DPI.

This sampler contains a selection of articles that have appeared in **RT** since the IPMS/USA National Convention in 2009. We've tried to show you what you can expect to see in **RT** with an IPMS Canada membership. Fortunately, with many good articles to choose from, it was tough to decide which articles to include here and which ones would not be showcased in this special **RT**. A normal issue of **RT** consists of 36 pages, containing 8 to 10 articles. Most of these articles are written by IPMS Canada members, and the contents of **RT** reflects the interests of the membership.

We hope you enjoy the following selection of **RT** articles and consider joining IPMS Canada!

Steve Sauvé
RT Editor
IPMS Canada
editor@ipmscanada.com



Table of Contents	
1/72 CF-101 Voodoo <i>Yves Fournier</i>	3
1/35 Sherman, Italy - 1944 <i>Gary Barling</i>	9
RCN's Anomalous Sea Furies <i>Leo Pettipas</i>	15
1/72 Boeing 40B-4 <i>Bernie Hengst</i>	17
1/48 Kawanishi N1K1 Kyofu <i>Randy Lutz</i>	21
1/35 Cdn Army Centurion Mk.V <i>Gary Barling</i>	26
1/400 HMCS Bonaventure <i>Ryan Cameron</i>	32

IPMS Canada National Executive

National Director **Jamie Leggo**
Treasurer **John MacDonald**
Secretary **Kevin Smith**
RT Editor **Steve Sauvé**
Chapter & Member Liaison **Gary Barling**
Circulation **John MacDonald**
Marketing **Vacant**
Special Products/Archives **Randy Lutz**
Graphics Consultant **Bob Migliardi**

IPMS Canada Web Team:

Team Leader **Kim Elliott**
Assistant Webmaster **Paulo Garcia**
Assistant Webmaster **Urs Hitz**

RT is the official journal of the International Plastic Modellers Society of Canada (ISSN 0380-8114). Contributions and enquiries should be addressed to:

IPMS Canada
Box 626, Stn B
Ottawa, ON K1P 5P7
Canada

or by email to: box626@ipmscanada.com

Membership, including a one-volume year subscription to RT is **\$30.00 CAD** per year in Canada, **\$36.00 CAD** in the USA, and **\$50.00 CAD** for addresses elsewhere.



Payment for membership can be done through PayPal at the IPMS Canada website

Please send only cheques or postal money orders payable to IPMS Canada. Payment may be made in your own national currency, using the conversion rate of the day found at:



All material in RT is strictly copyright and is available for reprinting only with the written consent of IPMS Canada.

Notice to New Readers

If you are interested, the articles seen here may still be available in their original format as a back issue of **RT**. However, please note that very few extra issues are ordered just to be stock on the shelf, waiting for someone to order them someday.

www.ipmscanada.com/rtbacklist.html

IPMS Canada members are advised to ensure that their membership is renewed as early as possible in the production and renewal cycle, in order to maintain their 'active member' status, and not miss out on a single issue of **RT**!



VOODOO TALES



By Yves Fournier, C#5232
St-Jean, Quebec
IPMS Ste-Hélène / IPMS Réal Côté

Revell's 1/72 CF-101

INTRODUCTION

The Canadian Armed Forces CF-101 Voodoo has always been a very mythical and impressive aircraft for me. I still remember climbing an old tree next to the Collège militaire royal de Saint-Jean, close to my

boyhood home, every year as a teenager when college graduation time came around. This was the perfect spot to admire the pair of Voodoos from BFC (Base Forces Canadiennes) Bagotville doing a flypast. Hence, one of the first kits I made as a young modeller was the Matchbox

1/72 F-101B, what a kit that was! Dressed up with Flight Colours decals mail ordered from Ottawa's Hobby House, references from an article in IPMS Canada's RT journal and a beautiful photo from the old Canadian Forces Sentinel magazine, I gave it my best effort and modelled a CF-101F from 410 Sqn.



Matchbox 1/72 kit as a CF-101F, Flight Colours decals, circa 1984

About 15 years passed and when the Revell kit came out I was in my 'Special Schemes' phase and made the 409 Sqn 'Hawk One' version with Microscale decals.

When Leading Edge Decals arrived with the line bird markings several years later, I was now in my 'Luftwaffe phase'. I bought the decals anyway and set them aside, knowing they would be used some day. This day finally arrived in March 2008 and I came back with a vengeance, making two Voodoos at the same time. It was a 'no-brainer' that one of the kits would be the same 410 Sqn bird I had made 25 years ago. I could not wait to put these two side by side and see what 25 years worth of modelling experience had done!

BUILDING THE VOODOO

The subtle differences between the 'B' and 'F' versions of Canadian Voodoos are often overlooked. The 'F' was used as a dual-control trainer with 410 'Cougar' Sqn, and then later with 425 'Alouette' Sqn after 410 stood down as the CF-101 training unit (410 then moved to CFB Cold Lake, AB in June 1982 in preparation to become



Revell 1/72 kit with Superscale decals, 409 Sqn, 'Hawk One' Special Scheme

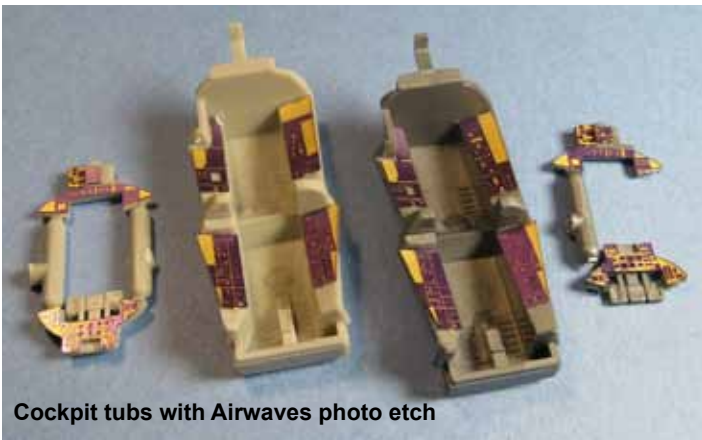

Cockpit tubs with Airwaves photo etch

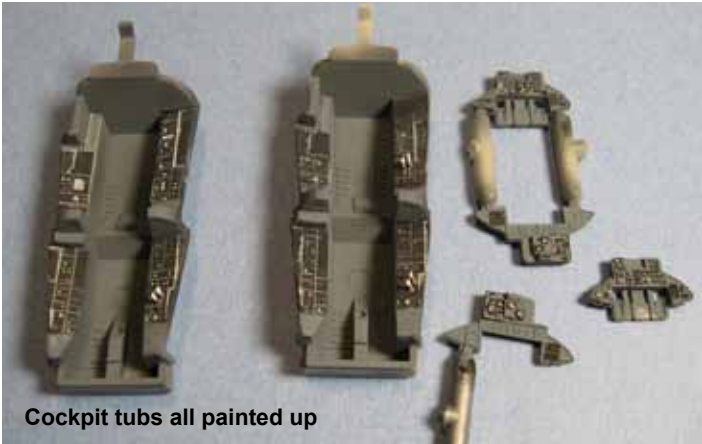

Cockpit tubs all painted up

the CF-18 OTU).

Aside from a few antennae, the only significant difference is two splitter plates in the inlet of the 'F' version (as opposed to one for the 'B') and differences in the instrumentation and scope arrangement of the cockpit. A list of the most helpful references for this aircraft is listed at the end of

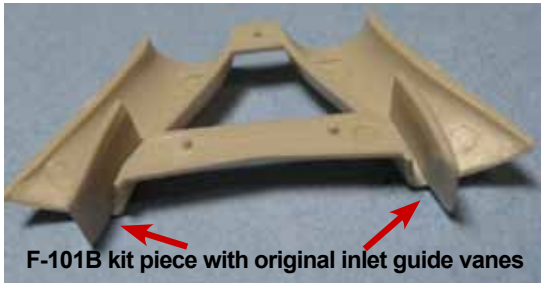

F-101B kit piece with original inlet guide vanes

- ◆ As they are too short I elongated the pins coming out the side of the main gear doors attaching to the gear legs.
- ◆ The engine inlet guide vanes from the kit were removed and replaced with thin plastic sheets. I spent a lot of time around the inlets getting



CF-101F Intake under construction



Completed CF-101F Intake

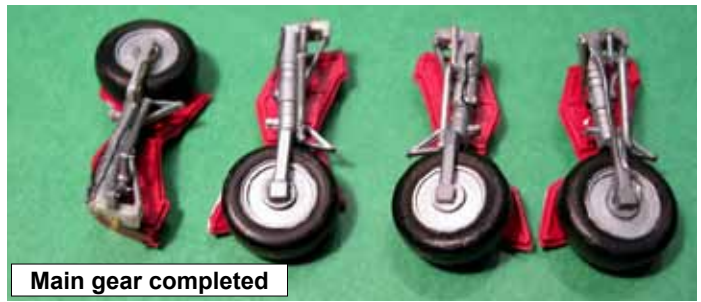

Main gear completed

Front wheel extension with copper tubing



this article. Not much aftermarket exists for this kit but I did use the Airwaves cockpit photo-etch as well as the True Details resin seats.

the inlet guide vanes to fit properly and eliminating any gaps around the inlets and wings. (Photos below)

- ◆ There are no positive attachment points for the main undercarriage gear legs and the location shown on the instruction sheet is not correct. I drilled a hole into the end of the legs and attached a metal rod. I added some plastic to the wheel well itself and drilled a corresponding hole into it. I thought this would work but it did not. This increased the height of the main gear legs so much that it gave the aircraft a serious nose-down attitude. I decided to remove the plastic from the wheel wells, then remove the metal rods, and then super glue the legs as best I could. Even then, since I glued them outboard as much as I could (not as per instructions but more realistic) the aircraft still ended up in a nose-down attitude. I thus proceeded to extend the front gear leg about 1/16", cutting and gluing some additional plastic rods as required.

- ◆ The auxiliary air inlets for the engines on each side of the fuselage were re-worked to the Canadian standard. (Photos on next page)



Details on the front landing gear

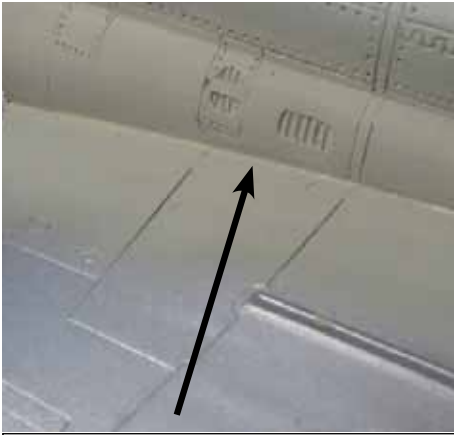

Auxiliary air intakes modifications

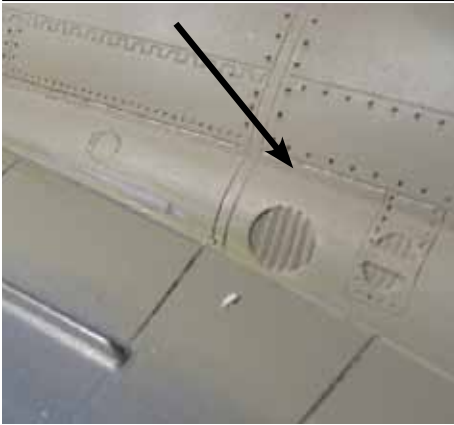

◆ The electroluminescent anti-collision strips were removed on the vertical tail and fuselage sides.

◆ The front landing gear, cockpits, and canopy need some detailing with wiring and other bits. Two prominent spring type devices were added to the front gear as well as two MV lenses for the landing lights.

PAINTING, DETAILING, WEATHERING

The model was airbrushed using an Iwata HP-C with Model Master Canadian Voodoo Grey enamel thinned with lacquer thinner. I actually had to build a spray booth for this as my local Health & Safety Inspector (*a.k.a. The Wife*) would not let me spray otherwise. After an application of Tamiya Gloss, and prior to the Leading Edge decals application, the panel lines were then accented using a wash of Windsor and Newton black thinned with mineral spirits. Left to dry for a couple of hours, the excess was removed with a dry tissue paper. When the recessed lines were not deep enough to 'hold' the wash, 3M sticky paper was used as a straightedge with a black pencil to highlight the panel line. Another light coat of Tamiya Gloss



sealed everything. I say light because if you go too heavy you will get a very gloss finish, which is not what I wanted. Spraying light allows a more satin finish which you can then polish to your liking with a cotton cloth. A slightly different approach was used for the other model where the highlighting was done with a Berol black pen, finely sharpened and worked into the panels. I found that when using a pencil, it is better to have a slightly more flat finish so the surface presents more 'grab' for the pencil.

The Leading Edge decals were then applied followed by another coat of Tamiya gloss. I sanded down the Tamiya Gloss with a 3200 grade sanding cloth prior to application of the final coat of gloss. This allowed the decal's edges to blend in more but unfortunately not totally disappear, as they are rather thick.

The air combat manoeuvring (ACM) coloured panels on top of the wings were then painted. Peeling and colour variations would be expected on these panels after

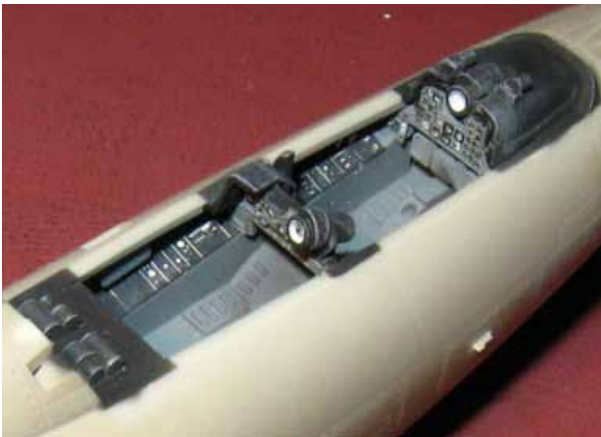

Cockpit details:
CF-101F above, CF-101B below



Panel highlighting:
Before (above) and After (below)



these are screen-resolution images



Decals on, starting to look good!



flying hours were accumulated. I chose not to reproduce these effects on my models, let's just say they represent "freshly painted ACM panels".

Bare metal foil was used to make the junction of the fuselage with the afterburner cans. A coat of Future was applied on each side of the foil to make sure it would stick to the paint well enough. The metal areas and the burner cans were sprayed next using Model Master metallic paint series. The metal panels were highlighted with several dry pastel shades to get the required effect.

The nose radome was not glued to the model and was painted gloss black without the pitot. A small hole was drilled into the pitot and the tip of the radome, a metal rod was inserted into this hole in the pitot. The pitot with the

rod were glued into the radome with cyano glue and sanded smooth for a nice joint. The radome fits snugly onto the fuselage and requires only a careful alignment to get a nice fit. The 'barber pole' red striping over the pitot tube was made with a thin red decal for one aircraft and painted red

after masking with Tamiya tape for the other as the decal would just keep on breaking.

The canopy was sanded smooth with 4000 to 12000 grit pads and then dipped in Future. The outside and inside were then masked with Tamiya tape and the Airwaves photo etch applied to the inside sills glued using watchmaker's glue. The yellow/orange/rust coloured band around the cockpit windows was made using Tamiya Tape, overpainted with a Steadtler fine line yellow pen, with removable ink. The tape was then coated with Future, left to dry and cut into appropriate size bands and applied to the canopy.

The interception identification light cover framing was hand painted Voodoo Grey. The round plastic 'light' was removed and replaced with an MV lens.

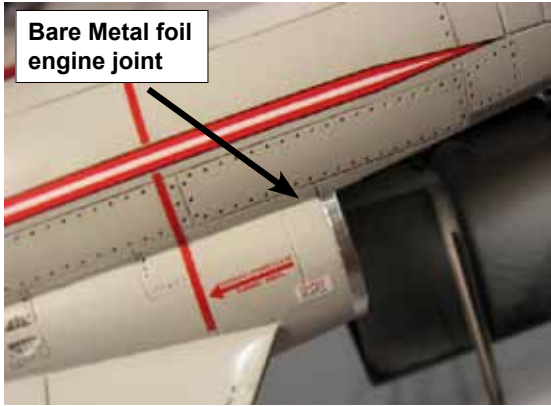

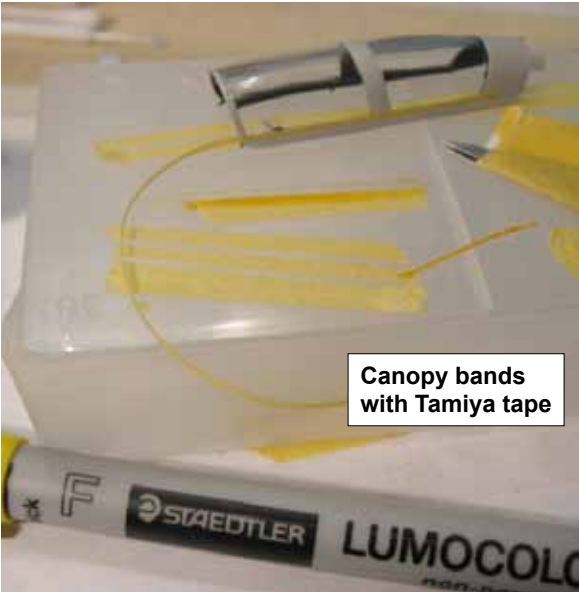

Canopy bands with Tamiya tape

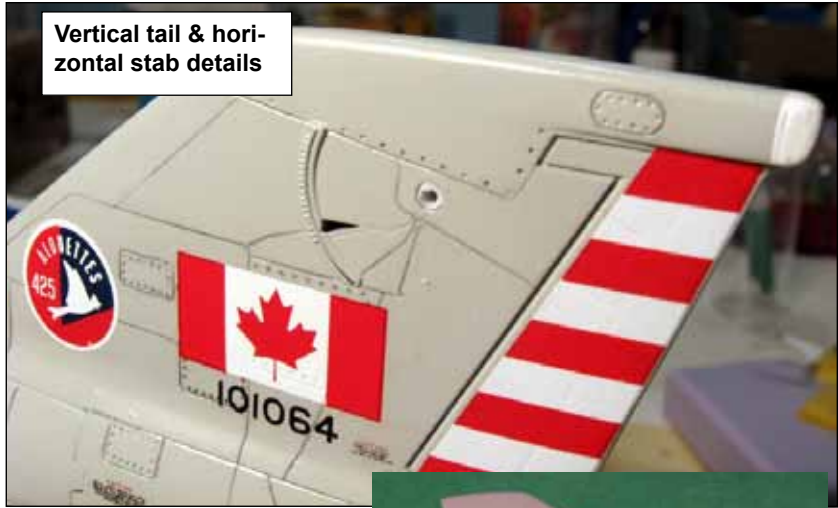

Vertical tail & horizontal stab details



The wingtip anti-collision lights were done using Premiere clear plastic lights.

The front windscreen was glued to the fuselage using watchmaker's glue. The canopy to fuselage seam was filled with white glue. I then filled and sanded all the seams smooth and sprayed the black antiglare panel.

CONCLUSION

It took the better part of one year almost to the day to complete these two models. This includes a summer break and I would say about one hour a day of actual modeling time. Both models now sit proudly in between a CF-104 and CF-5 on my display shelf.

REFERENCES

Magazines:

- ◆ Robbie Shaw, *Good Bye Voodoo*, Air Fan #77
- ◆ Peter R. Foster, *CF-101 in Canadian Service*, Combat Aircraft, July 97
- ◆ Ousmane Diagne, *F-101B Revell 1-72nd*, Replic #9, April 1992
- ◆ IPMS Canada RT, Vol 16, No. 4
- ◆ Marco Baltrieri, *F-101B Voodoo Revell 1-72*, Sky Model, Vol. 5, #15



MV lens aircraft identification light



Rear cockpit windshield details

The horizontal stabilizers locating pins were removed, holes were drilled, and a brass rod inserted into one of the stabilizers. The hole in the vertical stabilizers was filled with a plastic rod and drilled to accommodate the stabilizer's brass rods with a tight fit.

The rear cockpit windshield was scratch-built using transparent plastic sheets from a food container and the framing painted grey. This was glued to the rear of the front seat. The canopy opening cylinder was installed and the assembly glued in place. Finally, the front pitot tubes were glued as well as several antennas.

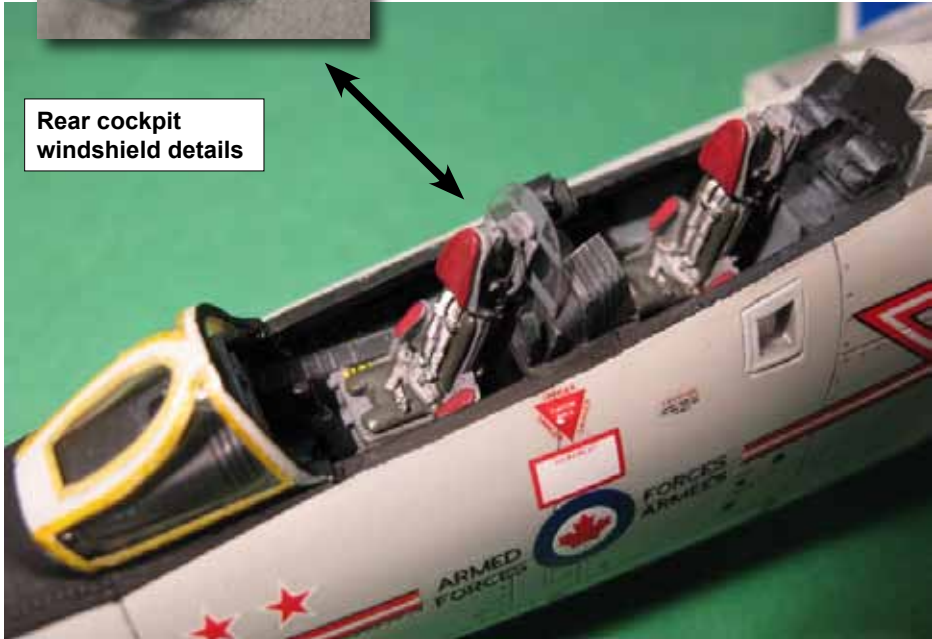



REFERENCES (continued)

Books:

- ◆ Robert McIntyre, *Canadian Profile CF-101 Voodoo*, Sabre Publications
- ◆ Kevin Keaveney, *McDonnell F-101B/F Voodoo*, Kevin Keaveney, Aerofax Mini-graph 5
- ◆ Peter R. Foster, *Century Series Fighter*, Osprey Series

Photos of CF-101s in museums:

- ◆ Air Defence Museum, CFB Bagotville QC
- ◆ RCAF Museum, CFB Trenton ON
- ◆ Canadian War Museum, Ottawa, ON
- ◆ Toronto Aviation Museum, Toronto, ON (open cockpit section only)

Websites:

- ◆ www.airliners.net
- ◆ www.jetphotos.net
- ◆ www.members.shaw.ca/waynehui.calgary/Gallery/Galley002/CF101.htm **RTI**

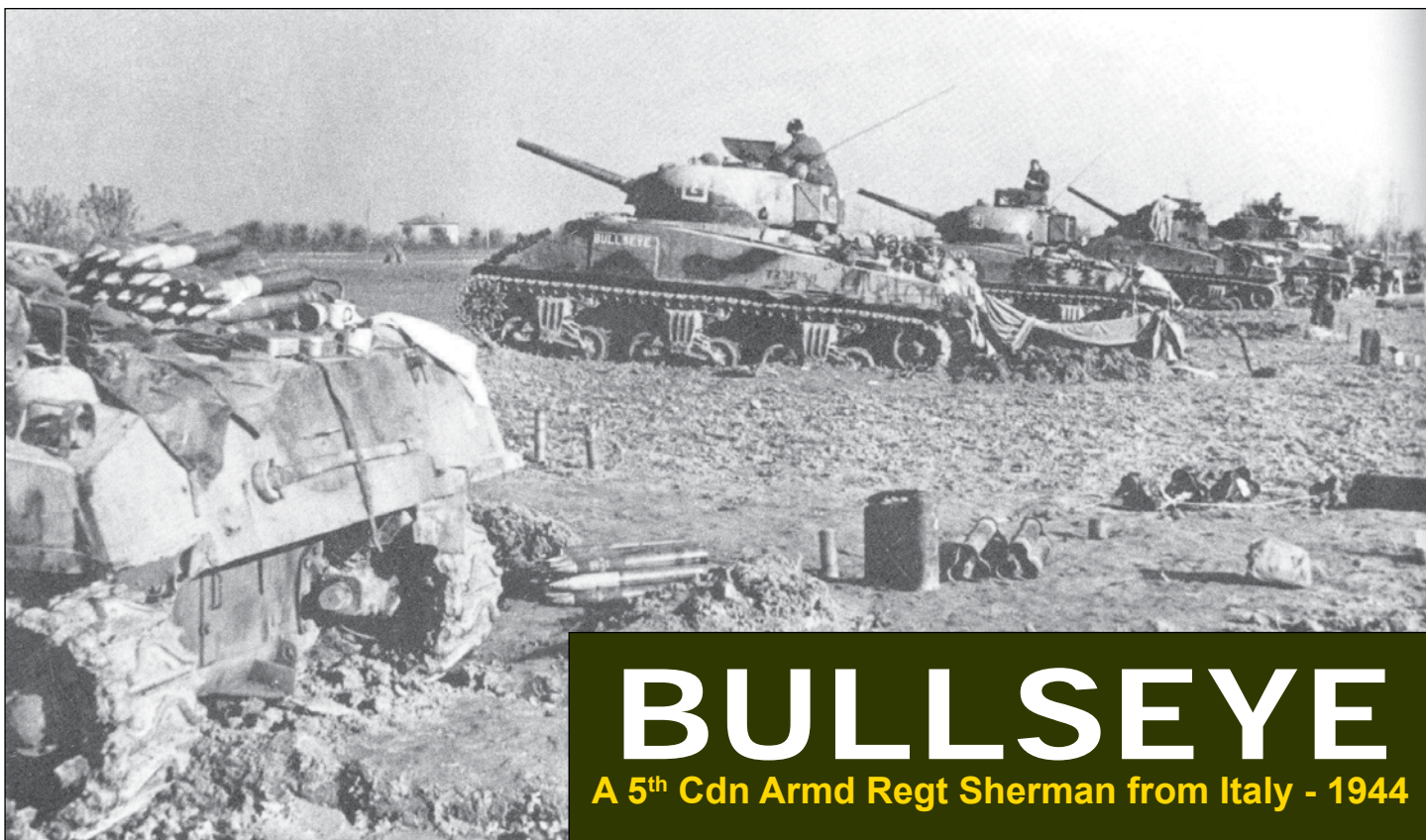

About the author:

 Yves Fournier was born in 1966 in St-Jean, Québec where he still lives with his wife, teenage son and daughter, and two cats. Influenced by childhood friends whose families were in the Air Force, he toured the airshow circuit, he developed a keen interest in modern military aviation and has been modelling aircraft since age 10. Following mechanical engineering studies at McGill University, Yves was hired by Pratt & Whitney Canada's Engine Design department and still works as a vibration specialist at their Longueuil headquarters today. Yves attends as many IPMS Ste-Hélène and IPMS Réal-Cote (Montréal) meetings as he can and enjoys participating in Torcan, CapCon and the occasional IPMS/USA Nationals with his modelling buddies.



BULLSEYE

A 5th Cdn Armd Regt Sherman from Italy - 1944

Sherman Vs in Italy wearing desert camouflage scheme rarely visible on Sherman V; centre, the "BULLSEYE" (WD Number T231758) of 2nd platoon, "B" squadron. [Tank Museum]

By Gary Barling, C#0014
IPMS Ottawa
Petawawa, Ontario



number of tanks built
by Germany from
1939-1945."
- Bruce Culver,
Sherman in Action,

Squadron/Signal Publications, p. 4.

Overview and Summary

Subject: Tasca Sherman V
Kit: 35-016
Scale: 1/35
Contents: Plastic parts (clear and light grey, many options), Photo-Etch, decals, comprehensive instructions
MSRP: CAD \$84.95 plus taxes

BACKGROUND 52

"The M4 Sherman tank is one of the most famous and significant armoured vehicles ever built. Rugged, unsophisticated and perfectly suited for mass production, the Sherman family eventually numbered over 45,000 vehicles, well over twice the num-

The design went through a myriad of modifications throughout its life: welded and cast hulls; multibank, air-cooled, radial, diesel and even aircraft engines; and thousands of engineering changes based on hard combat experience.



The M4A4 version was standardized in February 1942, fitted with a Chrysler multibank engine. This was essentially a set of five, 6-cylinder automobile engines grouped around a common drive shaft. This vehicle, designated Sherman V in British terminology, equipped British, French, Polish, Chinese and Canadian armoured units: few, if any, went to American troops. As Steve Guthrie states in his work on Shermans in Canadian service, "The Sherman may not have been the fastest tank of the war. It didn't have the biggest gun or the thickest armour. It was, however, the tank in which the vast majority of the Canadian Armoured Corps fought and won their war."

As noted, most of these vehicles went into British service and, as a result, it was



the tank used by the majority of Canadian tank units in the Second World War. The **8th Princess Louise's (New Brunswick) Hussars** (also known as the **5th Cdn Armd Regt**) were no exception, and took delivery of their Sherman V's in early 1944, on their arrival in Italy. As Tasca saw fit to produce a very nice Sherman V in 1/35th scale, I determined to build a representative Hussar Sherman V. The subject is 'Bullseye', a Sherman V from 'B' Squadron that was serving in December 1944 at Ravenna, Italy.

THE KIT 52

The Tasca kit of the Sherman V (Kit # 35016) was the basis for this build. The kit is one of the latest offerings from Tasca, a company that (I understand) plans to produce kits of virtually all of the major Sherman variants. Like the Sherman VC Firefly kit before it, the Sherman V kit is an excellent offering: detailed, accurate in scale and outline, and featuring a large number of extra parts. These include two styles of main suspension road wheels, two types of main armament and two types of machine gun port brackets. A fret of photo etch brass provides engine compartment and air intake screening, light brackets, sand shield mounting strips, and various small hull features. The instructions are complete, even to diagrams and templates for the appliqué armour and sand shield strips, as well as for the drilling of the 2-inch bomb thrower port in the upper turret roof and the mounting of the smoke grenade dischargers. This is not an inexpensive kit, but it is, in my opinion, very good value for money given content and quality.

CONSTRUCTION 52

Construction is, for the most part, straightforward. That said, it is important to em-

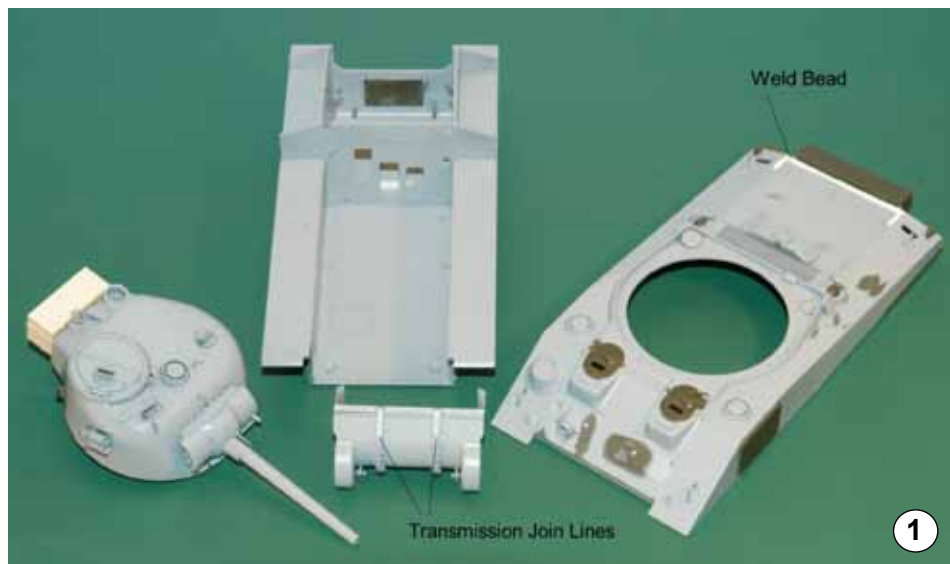

phasize right at the outset that there are some complexities to the build. However, these are easily dealt with if the instructions are read carefully and followed closely. An old and very applicable saying comes swiftly to mind: "When all else fails, read the instructions!" It is not essential that you follow the given sequence of major assemblies. You can tackle the suspension units first, or the hull, or the turret. What is essential is that you follow the instructions closely as you build the individual major assemblies. This particularly applies to the suspension units, as discussed below.

Hull: Unlike any number of other tank kits in this scale, the Tasca Sherman hull comes in several parts: left and right side panels, lower sponson panels, belly plate, rear plate, front transmission assembly and internal bulkhead. The upper hull requires the fitting of three access panels on the rear deck, plus a goodly amount of additional detail. The lower hull is one of the areas where you ought not to base your work on prior assumptions. Check the instructions, verify them, work slowly and you will find that, when finished, the upper hull will click into place like a well-made watch. The bulkheads and the locating features on the various parts almost guarantee a squared-off and well-aligned hull. My subject vehicle has the transmission cover in three pieces, each bolted to the next. The two bolting flanges are in two parts each, and when fitted together, show a slight gap that runs the length of each. This is correct, and should not be filled. The final drive housings (the pieces that extend forward on each side of the transmission cover) are also separate parts. Doing this does allow for better detail but you must contend with the seam that must be filled. While the fit is very good some

filling and sanding was necessary to eliminate the seam, since the real parts were cast with the outer transmission housing pieces. So I then had to go back and add the casting texture in the areas that were sanded. My preferred method is to use liquid glue like Tenax-7 and a stubby brush to stipple the area being textured. After it dries, a light sanding gives a great look. One reason I really like this method is that you can control where you put it so in this case I could redo the texture around the casting numbers without ruining them.

The upper hull required very little extra detail. About the only thing I did was to add a weld bead around the rear and sides of the rear access panel, which is not present because the rear plate is a separate part in the kit. I used a thin "worm" of Milliput, rolled out and placed along the two sides and the rear of the panel. I then "crazed" the worm into a weld seam by using a trimmed toothpick to replicate the welding appearance, and removing any excess Milliput. With the lower hull complete and the upper hull fitted into place, it's time to turn to the turret.

Turret: The turret construction is straightforward, once you know which of two gun/mantlet options you want to use (Step 20 or 21). The remainder of the construction is the fitting of hatches, smoke grenade dischargers, radio antennae, pistol port cover and assorted hardware such as lifting lugs. The turret ring fits well into the bottom of the turret proper, requiring only a small amount of filling and sanding around the rear bustle. Tasca provides an "all right" rear turret stowage box, but I had a spare Ultracast offering, and used it instead, gluing it into place with 5-minute epoxy and extending the moulded-on metal retaining strap with strip plastic. **(Photo 1)**

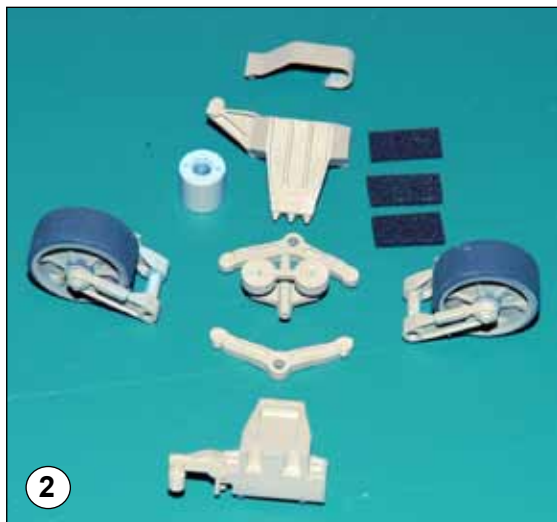

Suspension: The suspension is the most complex part of the build. In my opinion, this is because Tasca, wanting to “get it right,” did just that: the individual suspension units look great, but you have to assemble fifteen parts in a more or less



particular order to build each one of six units! (Photo 2). For me, this also requires the painting of the components before assembly (Photo 3). Again, it is vital to read and heed the instructions. This is not

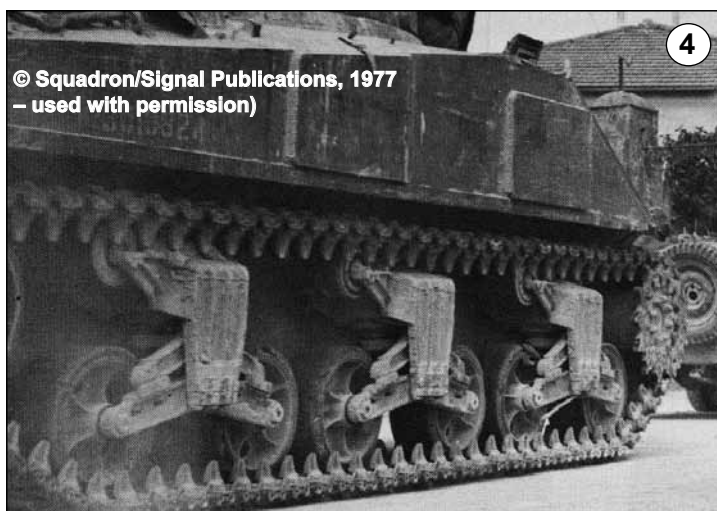

© Squadron/Signal Publications, 1977
– used with permission)

a complicated procedure, but it can be a little complex. The key problem area is the fitting of the wheel assemblies into the suspension unit housing. Essentially, the requirement is to dry-fit the entire suspension unit together (less the wheel assemblies), and then, while holding this grouping together, gently pry it open and slip the wheel assemblies into place. The assemblies will be positioned “forward” and “rear” on the suspension units. They can be fitted only as such because there are small pins of differing diameters on the wheel assemblies to be fitted into the correctly-sized reception holes in the suspension units. This ensures that the

suspension units are assembled correctly, but they can be a smidge frustrating to fit them together. However, they do look good when complete! I think that the units are engineered in this way to be sure that

the suspension (especially the wheels) aligns correctly with the tracks, once the tracks are fitted: no wheels end up “off the ground.” I employed a little poetic licence by using one or two spoked wheels in amongst the later solid versions.

I believe that these two types were interchangeable, and reflect the use of available stocks to maintain the vehicle’s mobility. The accompanying drawing and photo should clarify the requirements for the suspension units. (Photos 4 and 5)

Umm...have I mentioned the requirement to “read and follow the instructions closely” yet??

Tracks: The tracks come in two equal lengths for each side, and must be joined into a complete “loop” before fitting them to the suspension. The reason for this is that the tracks must be fitted in conjunction with the forward drive sprocket and the

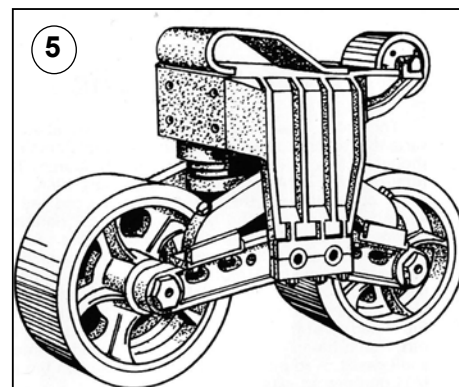

Early M4 Bogie Truck

© Squadron/Signal Publications, 1977
– used with permission)

rear idler wheel. For Heaven’s sake, don’t glue these two wheels in place before fitting the tracks. You’ll never get the tracks over the drive sprocket and under the forward hull and fender. The two wheels and the track loop go into place together, and this is called for in the instructions. I fitted the track to the sprocket, then fitted the sprocket in place, then gently ran the track over and under the suspension units, and finally slipped the rear idler into place. Have I mentioned...well, you know!! In their turn, the tracks got a coat of “Track Colour” from White Ensign Models (WEM), followed by a dry-brushing of Rub n’ Buff Silver to highlight worn steel parts.

Details: The tools included in the kit are well presented and provide a good selection. Each was separated from its sprue, cleaned up, painted appropriately and attached to the hull. I added several items of external stowage: storage boxes, spare road wheels, a duffel bag or two, water can and a small blue biscuit tin included in the kit.

MARKINGS 52

Painting: As many who know me are aware, in another life I was a long-time member of the 8th Canadian Hussars (Princess Louise’s). The parent unit of my Regiment was the 8th Princess Louise’s (New Brunswick) Hussars, which saw active service during World War Two in Italy and Northwest Europe. As noted above, the subject of this build is “Bullseye,” a “B” Squadron Sherman V of the 8th Hussars that saw service in Italy in 1944.

Disruptive Pattern: A somewhat grainy photo shows “Bullseye” in action at Ravenna, Italy in December of 1944. It is clear from the photo that the vehicle was finished in a disruptive pattern of a very dark colour applied over a lighter

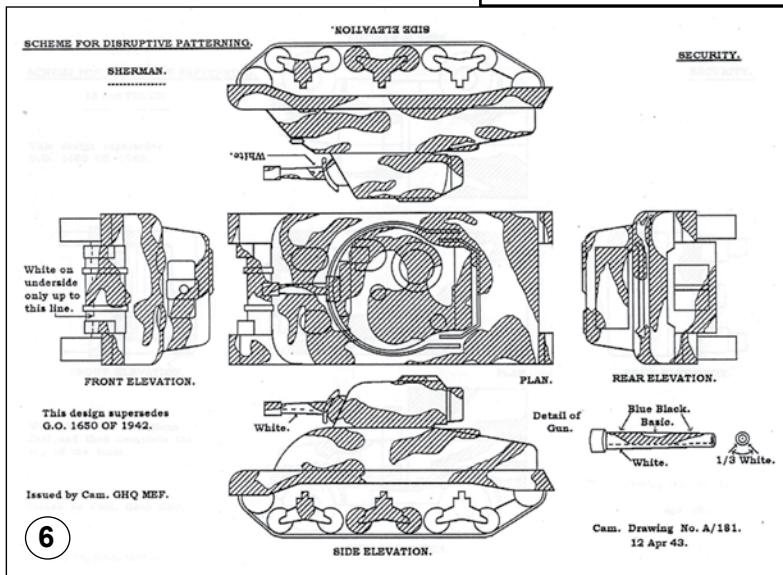

states, “desert camouflage”!

colour. My initial problem was two-fold: first, identify the colours, and then define the pattern. My first thought was that this might be a case of a random selection of whatever paint was available, and then applied in a random pattern. With only one side of the vehicle showing in the photo, the rest of the pattern might have to be “best guessed.”

Starmer Book: Fortunately, I came across a series of books by Mike Starmer. They deal with British vehicle camouflage before and during World War Two. He includes copies of the actual instructions and orders that stipulate colours and disruptive patterns, and then comments on the applicability and implementation of these orders. The result is a set of comprehensive references covering British vehicle camouflage from pre-War Britain through the desert, Sicily and Italy, to Northwest Europe. As much of the equipment used by Canadian Forces was drawn from British stocks, the camouflage information is directly applicable to Canadian units and formations.

For the purpose of this build, I needed camouflage information for the Italian Front. Mike’s book on British Middle East colours had the colour designation, colour chips (painted, not printed), plus the disruptive pattern diagrams applied by workshops to various vehicles. The colours designated for the build were Light Mud (a local Theatre colour) overall, with a Blue-Black (SCC 14 Blue-Black) disruptive pattern applied over it. Sure enough, there was a copy of the diagram used by the troops to paint Sherman tanks: top, front, back, sides and gun (**Photo 6** – used with permission). An email conversation with Mr. Starmer elicited the comment that



workshops applied the disruptive pattern as closely as possible to the drawings. Fortunately, the photo of “Bullseye” was clear enough to show that, while not 100% in accordance with the drawing, it was close enough to say that the pattern was mostly following the official requirement. **Note that the caption on this article’s lead photo of “Bullseye” incorrectly**

14 Blue-Black is exactly that. Do not use pure matt black paint, it is much too strong.” However, the order dealing with the change to the two-colour disruptive colours states in part, “The disruptive pattern will be in black, designated “blue-black”.” I think that the author here is suggesting a toned-down black to address the “scale





colour” issue for models.

Painting Techniques: I used Mr. Surfacer light grey primer from a spray can to prime all external surfaces, leaving them for a day or two to dry thoroughly. This provides a thin, uniform surface that accepts paint readily. The first colour applied was gloss white, sprayed onto the underside of the barrel and the lower front hull. This was used as countershading to minimize the shadows in these areas. With the white dry and masked off using a combination of masking tape and Maskol, an overall coat of Light Mud was applied to hull and turret (**Photo 7**).

Then came the fun part: masking off the Light Mud and applying the Blue-Black disruptive pattern. In a statement directly aimed at then future airbrush users, the applicable orders (dated April 1943) stipulate “If a spray gun is used, it is very important to spray the pattern to a CLEAR CUT EDGE [emphasis in original] by any means available. If the edges of the dark pattern are allowed to “blur off,” the object of the pattern will be largely defeated.” I tried several methods to achieve the clear cut edge: enlarging the pattern diagram to fit the model and cutting masks from it; masking using both freehand-applied Maskol and very thin strips of masking tape; and making masks out of frisket paper and BlueTac and applying them directly to the model. All of them worked fairly well depending on the surface painted, with the possible exception of the Maskol: I found that, upon removing the Maskol, I got a slightly jagged black edge with a little black paint residue, rather than the clean edge I’d expected. Eventually, I settled on drawing out the pattern with a black permanent marker, then masking over most of the marker line with Maskol.

(**Photo 8**) This effectively hid the slight “edge” that I was getting with Maskol alone. (**Photo 9**) Overall, the disruptive painting was the most laborious part of the build, but the end result was acceptable to me. As and when I build another Sherman in this scheme, I’ll probably paint the pattern before fitting any detail parts to hull and turret. Masking then should be much easier than with the detail parts fitted. Then, when the parts are subsequently fitted, they can easily be touched up using a fine brush.

I must also note that I used a little artistic license in applying the Blue-Black. From the photo of “Bullseye,” you can see at the rear of the left side of the hull that the painters did not quite follow the diagram. Accordingly, I did a bit of extrapolation when painting the back deck, but nothing too extravagant. I think that the problem was that the diagram was originally drawn from a very early Sherman, and the extended hull of the Sherman V didn’t quite line up with the orders.

Unit Markings: Ultracast puts out a very good line of decals in addition to their well proven resin accessories. One of their small sheets is for the 8th Hussars, and it is this sheet that I used. With the initial painting complete, I airbrushed a thin coat of Future floor wax over the entire model in preparation for decaling. (**Photo 10**) The balance of the markings (troop, squadron, unit and formation) came from the Ultracast sheet, and the vehicle name and serial number came from sheets of dry transfer markings from Archer Fine Transfers. Ultracast gives you two versions of the unit marking, a red square or a blue/green one. The question of which was correct has now been settled: use the

red square with the white “52” superimposed.

I apply waterslide decals using a drop of Future as the setting solution. When it dries, it tends to “suck down” the decal into every crevice and bend on the model. As well, it virtually fuses the decal film to the surface. Once all decals were in place, I sealed them in with a second coat of Future overall in order to protect the decal, blend them into the surface, and prepare the surface for weathering.

Oil Filter: With a coat of Future on the model, I decided to try something I had not tried before: applying a thin filter of oil paint to start to blend the two main camouflage colours. I used a 90:10 ratio of thinner (**Turpenoid**) to paint (**Windsor-Newton Black** and **Burnt Ochre** combined). I expected the Future to be a barrier between the camouflage paint and the Turpenoid, and it was...almost. In one or two small areas, the Turpenoid penetrated the Future (or I had not given the areas enough, or any, Future) and the WEM paint wrinkled slightly. I just waited until it was dry, then gently scraped the wrinkling away and repainted the area: a nuisance, but not a real problem. The darkened thinner imparted a slightly streaked and darker tone to the main cam scheme. When dry, I then applied a thin coat of Dullcote to matte the surface. I mixed in a drop of light tan to each ten drops of Dullcote to add a further element of blending onto the model.

Dusting: Yet another 10:1 mix of thinner and light tan, this time to selected areas on which dust would gather. These are mainly the horizontal surfaces: turret, hull, and suspension units.

Graphite: Using a small HB pencil, I lightly highlighted raised metal surfaces on the hull, turret, wheel rims and suspension. This gives a good representation of worn metal without making the surface overly bright

Pigments: The last item on the weathering list was to use pigments to add a bit more of a dusty, dirty appearance. This is another technique being used for the first time here by yours truly. I lightly applied Europe Dust, Dried Mud and Black Smoke from the Mig Pigments line using a small dry brush.

CONCLUSION 52

This was an enjoyable build, disruptive patterns and suspension units notwith-



◆ Michael Starmer, *British Middle East Colours: Tunisia, Sicily and Italy, 1943-45*, privately published, Piddington, UK, 2008.

RESOURCES 52

- ◆ Ultracast - www.ultracast.ca/
- ◆ Starmer Books and WEM paints – www.whiteensignmodels.com/
- ◆ Archer Fine Transfers – www.archertransfers.com/

SPECIAL THANKS 52

◆ Chuck Harransky, V-P of Squadron/Signal Publications for permission to use images from "Sherman in Action".

◆ Mike Starmer, for answering questions on the camo pattern and its application.



Re: Sherman V

"... I have to say that you have made a splendid job of (your Sherman), congratulations. One of the best renditions of the 1943 pattern that I have seen."

- Mike Starmer, author of *British Middle East Colours: Tunisia, Sicily and Italy, 1943-45*

standing. I find it most satisfying to come across related reference material that allows the accurate construction of a personally meaningful model. The kit is very nice, although expensive, and I can recommend it to modellers having average experience or more in the hobby.

REFERENCES 52

- ◆ Barry Beldam and Steve Guthrie, *Camouflage and Markings of Canadian Armoured Vehicles in World War Two*, Model Centrum Progres, Warsaw, Poland, 2009
- ◆ Bruce Culver, *Sherman in Action*, Squadron/Signal Publications, Carrollton, Texas, 1977.
- ◆ Steve Guthrie, *The Sherman in Canadian Service*, Service Publications, Ottawa, Ontario, 2002.



52

About the author:

Gary Barling was born and raised in the Toronto area and subsequently served 40 years in the Canadian Army and has been retired since 2004. Modelling since 1955, his main area of interest is aircraft, with strong minors in armour and ships. Gary's been a member of IPMS Canada since 1965 and currently the Chapter Liaison Representative on the IPMS Canada National Executive. He maintains dual citizenship in both IPMS Ottawa and IPMS Farnborough, England.

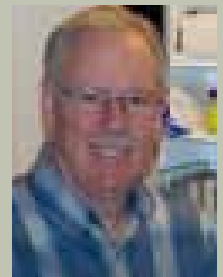



THE NAVY'S ANOMALOUS SEA FURIES



By Leo F. Pettipas,
Winnipeg, Manitoba

Long-standing members of IPMS Canada who like Hawker Sea Furies will no doubt recall Volume 6, Nos. 1&2 (1973) of *Random Thoughts*, which featured the "North American Sea Fury Special" written and illustrated by Bob Bowles and Ray Cryderman. From a modeller's standpoint, it was at the time by far and away the best publication available on the topic of Royal Canadian Navy Sea Furies.

The "Sea Fury Special," like many other historical-type articles appearing in modellers' magazines, involved a bit of educated guesswork made necessary in order to fill in gaps in the authors' available information base. As time goes on and as further research is done, new data often come to light that call for updates of and corrections to earlier statements in the older publications. The purpose of this article is to do just that regarding one particular conclusion drawn in the Bowles & Cryderman study, and to add further to the specific topic in question.

RCN MARKING STANDARDS

Until the latter half of 1952, RCN aircraft appeared in the marking scheme called for under the ICAO system instituted in 1947. Initially, individual a/c carried a three-letter code on both sides of the fuselage and under the port wing. The first two letters identified the squadron to which the airplane belonged, and the third, the particular machine carrying it (Fig. 1). Pat Martin (Royal Canadian Navy Aircraft Finish and Markings 1944-1968) refers to this as the "VG Era."

With 1952 came a major change in the way in which the Navy marked its aircraft (the "NAVY+3 Era"). The ICAO call letters were done away with and replaced with the word NAVY and a three-digit radio call number. On most operational aircraft, the first digit equated with the crew structure of the machine. Since the Sea Fury was a single-seater, the first numeral in the series was to be, in theory at least, a "1" (e.g., as shown in Fig. 2).

AN EXCEPTION TO THE RULE

In their RT article, Bob and Ray refer to a set of drawings appearing in the January and February 1963 issues of *Model Airplane News* (MAN). These drawings depict RCN Sea Fury TF 996 bearing the call number "254." Bob and Ray were well familiar with the new markings system, and since 254 obviously doesn't fall within the 100 series of numbers, they questioned the historical correctness of its appearance in the drawings. Rather, they regarded it as a "long perpetuated error," and went on to write: "At the risk of putting our heads on the block, we'll go so far as to say, **NO R.C.N. SEA FURY EVER CARRIED THE SIDE NUMBER 254!!**"

Bob and Ray were also familiar with an official Navy manual detailing the new (1952) Sea Fury colour scheme and markings. This manual showed the number 254 on general arrangement drawings, but they interpreted this as simply an idealised schematic generated for instructional purposes, rather than as a representation of an actual airplane. They suggested that the MAN draughtsman may have worked from the contents of this manual, hence the "spurious" number 254

appearing in his drawings.

CONFIRMING EVIDENCE

Significantly, Sea Fury TF 996 is shown to have carried the call number 254 in John Griffin's authoritative *Canadian Military Aircraft Serials and Photographs 1920-1968*, the data for which were drawn from official DND files. John's information is confirmed in Alexander Grant's more recent *Tabulated Histories of the Aircraft of the Royal Canadian Navy and the Canadian Armed Forces (Maritime Air Group) June 1945-May 1997*, also compiled from official DND documents. TF 996 was the actual serial number of a real airplane, and with that in mind I had to wonder why the Navy would have chosen to combine a "bogus" radio call number along with a bona fide serial number in the drawing in its manual.

Today, the weight of evidence leads me to conclude that TF 996 did indeed carry the radio call number 254 at some point in its career, although I've personally never seen a photograph of it bearing that number. Nor



Fig. 1. Sea Fury TF 996 showing her call sign BC*K of the 'VG Era' (1947-1952). Credit: W.R. Crosby/National Archives of Canada/PA-134183.

can I explain why a front-line single-seat aircraft received a **200**-block side number. But -- and this is where things really get interesting -- I do have photos of it carrying the call number **294**! **Figure 3** shows this airplane with all port fuselage markings plainly visible. It would thus appear that **TF 996** temporarily

bore **254** before that number was replaced by **294**. Or, it was assigned **254** on paper, but it was never actually painted on the aircraft, **294** being applied instead. Whatever the case, I think we can reasonably conclude that the reasons for such changes are forever lost in antiquity!

AN ADDITIONAL DEVIATION

As I say, it's by no means clear to me why these departures from the standard practice of allocating **100**-block call numbers to single-seat operational squadron Sea Furies were deemed appropriate in the case of **TF 996**. But to add to the puzzle, it happened twice; only on the second occasion, the number in question was drawn from the **300** block: the Sea Fury bearing serial number **WZ 636** received the call number **354** (**Fig. 4**).

Pursuant to the standard radio call number system applied to operational squadron aircraft, numbers in the **300** range were, logically enough, usually allotted to the Navy's three-seat TBM Avengers. And indeed, number **354** was carried by one of the Avengers (serial number **69425**), as we might expect. What it was also doing on a single-seat Sea Fury is anyone's guess.

CONCLUDING REMARKS

While atypical markings do raise "why" questions which, after all these years, are pretty well impossible to answer, they do offer opportunities to the modeller who wants to replicate something that's different and unusual and yet a genuine piece of our aviation history and heritage.



Fig. 2. Typical markings scheme of the NAVY+3 Era Sea Furies, showing the 100-block radio call number. Credit: Western Canada Aviation Museum 31965.



Fig. 3. Sea Fury TF 996 clearly showing the side number 294. Credit: R.E. Quirt, via S. Soward.



Fig. 4. Sea Fury WZ 636, showing the atypical 300-block radio call number 354. Also non-standard is the "square" style of the numerals (compare with those shown in Figure 2), suggesting that they were applied at the British factory rather than in Canada. Credit: MAP



About the author:
Leo Pettipas is a native of Halifax, now living in Winnipeg. A former Honorary Historian with Winnipeg Chapter, Canadian Naval Air

Group (CNAG), he authored seven books and was recognised nationally as CNAG's 1986 Member of the Year. He has published over 50 articles on Canadian military aviation in Canada and the USA. He was Editor Emeritus of *Certified Serviceable: Swordfish to Sea King* (1994), covering the support elements of Canadian Naval Aviation, and technical advisor in the preparation of Patrick Martin's book, *Royal Canadian Navy Aircraft Finish and Markings 1944-1968* (2007). In 1999 he was appointed an Associate Air Force Historian at 1 Cdn Air Division, Winnipeg. In this capacity he co-authored the 2007 book, *402 "City of Winnipeg Squadron History: On Guard for 75 Years*.

CMR's 1/72 Boeing 40B-4

By Bernie Hengst,
C#2020
IPMS Toronto



Introduction

The Boeing 40 is the best-remembered mail and airline plane of the late 1920s and early 1930s. It was introduced in mid 1929 and served with eight American and one Canadian airline. A number of large corporations also used them for executive transports. The 81 Boeing 40s built in America and Canada made up the largest commercial plane order for airmail and passenger service up to 1930.

Airmail service started in the US on May 15 1918 with Curtiss JN-Jenny trainers supplied by the US Army to the Post Office, and flown by US Army pilots. The 2,600 miles (4,128 km) from New York and San Francisco, via Chicago, was opened between May 15, 1919 and September 8, 1920. Newly acquired Standard and surplus Liberty-engined Airco D.H.4M biplanes were used by the Post Office for the next eight years.

In February 1925 the Air Mail (or "Kelly") Act was passed, providing for the transfer of the services to private companies. The contract for the Chicago to San Francisco section went to the Boeing Airplane Company and Edward Hubbard, and later to Boeing Air Transport (BAT).

Work started on twenty-five Model 40As, powered by Pratt & Whitney Wasp 420 hp engines. The Boeing Model 40As had room for two passengers, later the Model 40Bs, powered by 525 hp Pratt & Whitney Hornet engines, could transport four passengers.

The Kit

This is another CMR kits that my friend Bill Coffman gave me to build. The kit contains 75 beige and four clear resin parts, a fret with 45 pre-

painted etched parts and two vacuformed windscreens. All the parts are packaged in a sectioned plastic bag, to avoid scratching and breakage of the small parts. A very nicely printed decal sheet for four different aircraft, a sheet with masks for the tail surfaces, four pages of instructions, four pages of coloured painting and decaling instructions and four pages with information and black and white photos of some of the original aircraft, make up the remainder.

First Steps

Construction started with removing the fuselage parts from the casting blocks with a saw and carefully cleaning them up with a fine file and wet sanding. Wearing a dust mask is a good safety precaution for doing these jobs. I was amazed at the quality of the resin castings; I found less than ten pinholes and those mainly on the leading edges of the wings. The parts were washed in soapy water and left to dry.



Here the fuselage halves have been sprayed beige on the ceiling and the pilot's cockpit, and light brown for the lower part of the passenger compartment. The floor is sprayed medium grey.

Cockpit and Engine

The inside of the fuselage halves and cockpit bulkheads were sprayed Model Master Radome Tan FS 33613. When dry the fuselage halves above the windows and the passenger bulkheads tops, as well as the complete cockpit area were masked and

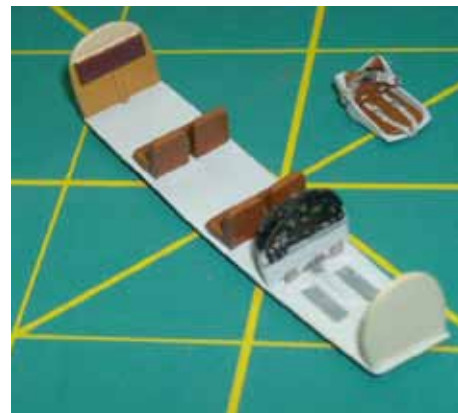

Interior insert showing the passenger seats and the instrument panel and rudder pedals. The pre-painted instrument panel is beautiful and is supplied with the kit.



the parts sprayed with Humbrol Matt # 62 Light Brown. A day later the brown parts were masked and the floor in the passenger compartment and cockpit were sprayed Model Master FS 36495 Light Grey.

While the paint dried during the next few days, I filled and wet sanded the leading edges of the wings. Cleaned-up the tail surfaces, wheels, landing gear struts, engine (I used the solid cast one – (a second engine with separate cylinder heads and a crankcase is also included), exhaust collector

ring, exhaust pipe, a cover for the exhaust collector ring and head rest fairing that I needed for the replica that I was building.

The seat belts were added to the silver sprayed pilot seat. Do not assemble the seatbelts and try to add them to the seat but install them piece by piece (the seatbelts are made up from eleven beautifully pre-painted parts. If assembled first it will be impossible to bend them to fit the seat. I painted the passenger seats Humbrol Matt # 63 Medium Brown and installed them when dry.

Etched parts, throttle and handles for the cockpit sides were carefully cut from the fret, bent and installed with CA glue as well as the rudder pedals on the floor and the instrument panel, very nicely pre-painted, on the front cockpit bulkhead. The painted control stick and the finished seats were set aside to be installed later, as I wanted to use tissue paper to blank the cockpit area for spraying. I masked the passenger windows on the starboard fuselage from the inside with small strips of Tamiya masking tape. The passenger and cockpit sections were fastened to the starboard fuselage with CA glue and the fuselage closed. The headrest fairing, after some sanding and test-fitting was added and CA glue was used to fill the fuselage seam.

As I wanted to show the two doors to the passenger compartment open, I stuffed wet tissue paper in the opening for the later spraying sessions. The clear cast resin doors had the window sections masked from both sides and a 10. thou plastic card was used to thicken the door below the windows to give it the look of the doors as seen on the colour photos seen on the recently restored Boeing 40B-4 found on the Internet. The inside of the door was painted Humbrol # 62 Light Brown and the outside would be sprayed with the fuselage sides and wings "French Grey".

Fuselage

The fuselage seams were rubbed down with just a couple of sections being retreated. The headrest fairing was another matter. Two more fillings with CA glue and than two applications of Mr. Surfacer 500 were necessary to blend it smoothly with the fuselage. I drilled holes in the rudder (2 x above and below the elevator) and elevators for operating arms and installed the vertical tail surface. Before the horizontal tail surfaces were added, I drilled all the holes for the rudder (4x) and elevator (2x each side) control wires in the rear fuselage. The seams were filled and rubbed down and the struts installed underneath the horizontal tail surfaces. Next, the tailskid and housing was added and when set the skid part was cut off, a hole drilled into the housing and a short section of slightly bent brass wire was glued in place.

The fuselage, upper and lower wings as well as the wheels were primed with Tamiya grey primer. After 24 hours of drying, they were lightly sanded and some areas re-primed. While this dried, I mixed the "French Grey", "Boeing Green" and International Orange.

Colour Scheme

The "French Grey" was mixed from Model Master Light Gray FS 36495 to which I added a few drops of Humbrol Gloss # 101 Green. For the "Boeing Green" Humbrol Gloss # 101 Green was lightened with Satin # 130 White. When making a test colour card of the Model Master International Orange, I found it too red and dark in comparison to the colour pictures I got from Bill Coffman

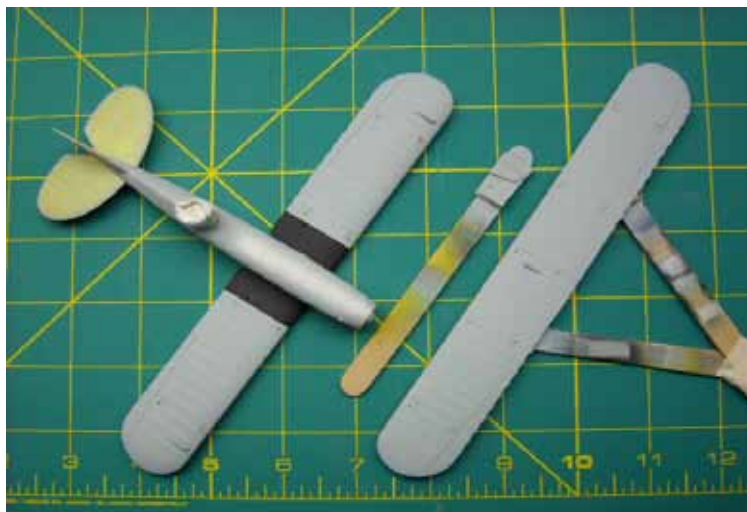

The grey colour has been applied to the upper surface lower of the lower wing and the lower surface of the upper wing. The wing walk-ways are sprayed black and the tail surfaces have the supplied masked applied. These masks had to be trimmed slightly to fit them properly.

showing Boeing 40B-4 in the Henry Ford Museum and the Chicago Museum. I added Model Master Bright Yellow to the Model Master International Orange until it was lighter and more orange coloured.



Having read the Boeing 40B-4 write-up in Scale Aviation Modeller International, Vol. 15, Issue 1, January 2009, I filled the rear outside locating hole on the lower wing for the strut and drilled a new one 1.5 mm forward of the original location. On the fuselage and on the wings holes were drilled with a number 80 drill for the rigging wires (double wires on the wings. Also drilled were holes for the aileron control wires above and below the wings. The lower wings were installed and wooden stir sticks were put under the wing tips to ensure the 2° dihedral. After the CA glue had cured, the seams were filled and sanded.

The "French Grey" was sprayed on the fuselage sides and all tail surfaces and to the lower part of the upper wing and the upper part of the lower wing.

Masking Time

After drying for 24 hours, it was time to apply the supplied masks for horizontal and vertical tail surfaces. Before I glued these parts to the fuselage, I had placed these parts onto the decal sheet to confirm the later placement of the thin orange-red strips. I knew that I would have to modify the masks to make things later fit better and that I had to

trim and/or cut the decals to make them fit. To make the masks fit better I scanned the decal sheet and cut the tail surfaces out on the orange-red line, trimmed them to fit the tail surfaces correctly and used the cut-outs to trim the masks accordingly. On the masks for the vertical tail, I cut 1 mm. of the rear and on the horizontal surfaces, a sliver was trimmed from the rear section and about 2 mm. were it fitted to the vertical tail.

The fuselage mask was not supplied but was easily made with a circle cut from Tamiya tape and cut in half and placed just in front of the leading edge of the lower wing.

The dimensions for the circle came from measuring the fuselage and it was a little smaller than the decal sheet dimensions. The rest was covered with strips of Tamiya tape, using pictures and the colour instruction sheet as a guide.

After the lower wing was masked with paper and tape, the "Boeing Green" was

The "Boeing Green" has been applied. This paint was mixed to match pictures of the aircraft in the Chicago Museum



The orange has been applied to the upper surface of the upper wing and the lower surfaces of the lower wings.

Decaling has been started. Some trimming had to be done to the decals on the tail surfaces and fuselage sides.

The decals went down beautifully and were easy to be handled on the model.

sprayed onto the fuselage, the edge of the tail surfaces, the cowl cover and wheels. Left to dry for two days, the masks from the lower wings were removed and the grey areas of the lower and upper wings masked as well as the bottom of the fuselage to spray the orange-red colour. To do that correctly I installed the landing gear struts so that the model could rest on them while the underside of the lower wing could dry. Before the colour was applied, the photo etched control horns were folded and added to the ailerons and the grey areas masked. After spraying the orange-red the model was left again two days to dry.

So that I did not break the control horns off while handling the model to install the struts

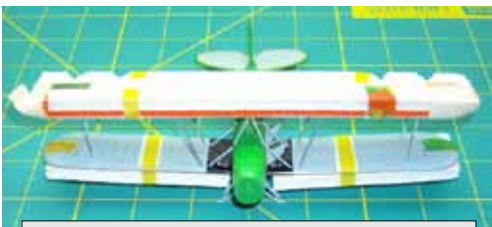

I stuck foam board to the upper and lower wings with thin strips of Tamiya tape, to make handling easier and prevent damage to the paint finish and decals while fastening the upper wing to the model and adding all the struts. Rigging is about to commence.



and applying the rigging, I cut foam board to fit the wings

Markings

horns. I can say now that it worked very well.

The last items to be sprayed were the black wing walking areas.

MARKINGS

The decals made by "Stanislav Mach" are excellent and settled down nicely with only small amounts of setting lotions. I started applying the decals on the lower

horizontal tail surfaces first. The decal for the thin orange outline were cut lengthwise and slightly overlapped at the wing tips. No change of colouring was noticed on the small over-laid orange colour sections of the decal. I was pleased and tackled the upper horizontal surfaces next. On the vertical tail decal I cut 1.5 mm. off the back, just behind the lettering, installed the front parts on both sides using plenty of water to slide them into place. After they had dried, the small back sections were added.

The large fuselage decal was installed in sections. The rounded front section was cut off (6 mm.) and the clear decal part on the inside was trimmed very closely to the orange line. This allowed me to curve it inside the green outline and leaving an even grey line between the orange line and the green fuselage paint. The rest of the fuselage decals were added in sections and the registration on the upper and lower wings. All the decals were sprayed with Floquil Crystal Cote mixed with a few drops of Floquil Flat Finish to seal them in.

Fiddly Bits

It was time to install the struts. First to be installed were the short lower wing to fuselage struts. Also, the doors were installed at this time, as it would be difficult to add them when the upper wing was on and the windows on the starboard fuselage were filled with Humbrol Clearfix. To install the upper wing I glued the two outer struts onto the lower wing, carefully checking that they were parallel and measuring that the distance between the left and right set of struts matched the locating holes on the upper wing. An hour later, I added the upper wing and left the CA glue to cure overnight.

Close-up of the port front fuselage, showing the instrument on the front of the wing and the open doors.



Next, the cabane struts were installed. I did this while kneeling in front of the workbench, this is also a good position to say a little prayer, while installing these small and fiddly parts! To add the angled inboard struts I filled a slight angle at the ends and drilled holes into the ends. Small pieces of sprue were glued into the holes and trimmed to about .5 mm. This made it easier to locate the struts and keeps them in place while the CA cured. With all the struts in place the upper wing to fuselage and lower wing structure felt very solid and with the foam board in place it was very easy to handle the model while installing the rigging.

I rig with stretched sprue and it was a full evening's work to complete it. I started with the rigging the near the cabane struts, then the angled struts and finally the outer struts.

Next came the double flying wires, four on each wing from the lower wing near the fuselage to the upper wing outboard struts. These were tightened with a lit incense stick.

Make sure you keep the heated part moving lengthwise or you start rigging again! The support wires were installed next and this is always fun double-wired planes because one of the wires has to be installed between the flying wires. Nevertheless, I got it done too and damaged only one of the flying wires.

The control wires for the rudder and the elevators were added, as well as the tail support wires.

The foam board was removed; the aileron control wires were installed on upper and lower wings and the aileron interconnecting wires.

I added the seat, control stick, windscreen and the wheels. I had earlier drilled the holes for the aerial mast in the fuselage and aerial wire in the leading edge of the upper part of the vertical tail. I used .81 mm brass wire for the aerial mast and installed the pre-painted mast with CA glue. The two short aerial masts were added to the upper wing and painted International Orange. When dry the aerial wires, again using stretched sprue



Showing the open doors. They are supplied in clear resin. I clued plastic sheet on the bottom and framing around the windows to the door some depth as shown on pictures of the real aircraft.

look forward with anticipation to further releases.

References

- ◆ Air Enthusiast, Number Twenty-two, 1983,
- ◆ Fine Scale Modeler, October 1986,
- ◆ Scale Aviation Modeller International, Vol. 15, Issue 1, January 2009,
- ◆ Pictures from Bill Coffman and from the Internet.



Here the decals are shown on the on the port side of the fuselage. I managed to get the "Boeing Pacific Air Transport" logo in the right position and between the orange trim lines.

were installed and tightened.

The engine with pushrod made from silver stretched sprue had the cowl cover glued with a few tiny drops of CA. The collector ring was added and the engine installed. After the glue had cured, the tailpipe was installed and when this had set the contacts touched up with exhaust paint. The edged pitot tube was folded and installed on the starboard front strut and filler caps and what looks like an instrument were folded and fitted to the inboard wing near the leading edge. Finally, the finished propeller was added and the model was completed.

Conclusion

I found the model an interesting and enjoyable build, with very few problems. The finishing was an exacting task, and not for the faint of heart! This manufacturer continues to issue kits of great interest, and I



About the author:

Bernie Hengst was born in Germany, where he apprenticed as a butcher and as a cook; he also served for a year in the West German Army. Immigrating to Canada in 1963, he worked in the Chateau Fontenac, the Royal York Hotel

and the Scarborough Golf Club; he then taught cooking for 30 years. He is also an avid gardener.

He started modelling at age 12, carving models out of wood. Building paper models came next and the first plastic model was a Renwall 105 mm Howitzer. After building a few armour dioramas he switched again to 1/72 scale aircraft.

Bernie has been an IPMS Canada and IPMS Toronto member since the early 1970s and is also a member of the Toronto Aero Buffs.



BUILDING TAMIYA'S 1/48 KAWANISHI N1K1 KYOFU AS A 'REX' OF THE 951ST KOKUTAI, SASEBO NAVAL AIR BASE, JAPAN, DECEMBER 1944



By Randy Lutz
C#4650
Ottawa, Ontario



N1K1 BACKGROUND

During 1940, the Imperial Japanese Navy (IJN) recognized that there was an impending clash with the United States in the Pacific. As a means to meet this coming conflict, a requirement was tendered for a floatplane fighter.

An interim aircraft was already in the works (*the Nakajima A6M2 N 'Rufe'*), but there was an apparent need for a purpose built floatplane and not the stopgap modification currently proposed.

Kawanishi responded with a design powered by a 1,460 hp Mitsubishi MK4D Kasei 14 engine driving two contra rotating propellers. This initial design was to have a

central float with two retractable outrigger floats. Kawanishi experienced numerous problems with the outrigger floats during the testing program and subsequently modified them to a non retractable design.

The prototype N1K1 first flew in mid-1942 and problems were immediately encountered with the propeller gearbox. These problems forced the Kawanishi design team to abandon the contra rotating props in favour of a more conventional three bladed arrangement, which was incorporated in the second prototype. This model was fitted with two wing mounted 20 mm cannon and two cowl mounted 7.7 mm machine guns. The Kyofu (*Mighty Wind*) Model 11 (*correctly spoken as 'one one', not 'eleven'*) as it came to be known, met all of the Navy's expectations. As a result, it was ordered into production, with deliveries commencing in the spring of 1943.

Warfare being what it is, nothing remained

constant, and the IJN soon found itself in a defensive role. More and more, the Navy was relegated to fighting from land bases, and the 'Rex' proved to be ill suited for this new environment. Consequently, production was halted on the Kyofu in favour of a land plane version, which would meet the needs of a defensive fighter. This new fighter was to become the N1K1 J Shiden, Allied code name 'George'. The total production for the 'Rex' amounted to a mere 97 units. This is the only aircraft that I am aware of that started life as a floatplane and was converted to a land based aircraft.



THE KIT

Tamiya's Rex is now going on 14 years old and, given the improvements we have seen in the industry over the past few years, it still holds its own in terms of detail and ease of assembly. It does not have a huge part count, coming in at a svelte 38

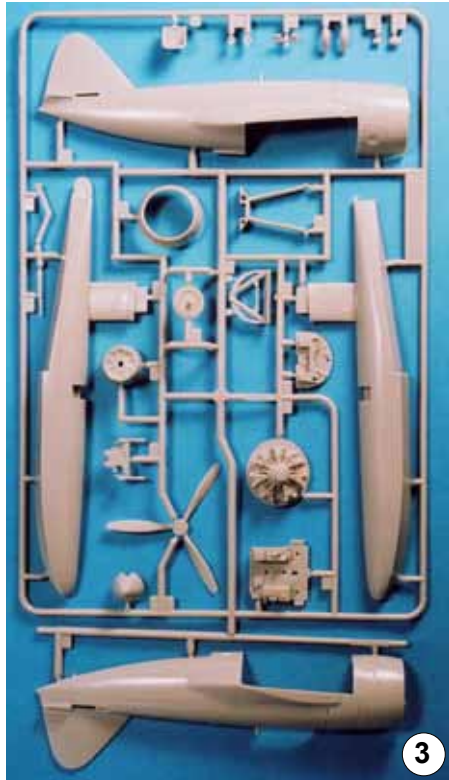

area was airbrushed with Xtracolor X261 Olivgrun RAL6003. This colour is a near perfect match to the colour chips found in the Asahi Journal and the Model Art on the George/Rex. The only other thing I had to do to the cockpit was to drill out all the lightening holes in the pilot's seat. I applied a wash to the cockpit parts using a mixture of X261, Winsor & Newton Ivory Black oil paint and turpentine. This was followed by a few coats of Testors Dullcote and then some dry brushing using a mix of X261 and Winsor & Newton Titanium White oil paint. Some ground up pencil lead was rubbed into the floor boards in the area of the rudder pedals, and the rudder bar assembly was airbrushed a generic dull silver. I installed a set of Eduard photo etched seatbelts after they were airbrushed with Testors Leather. I don't use the pre painted etch as I do not feel the impression is as nice as I can achieve on my own using paint. Note that in the case of the Rex and the George, the lap belts actually fasten to the inside of the seat. In **Photo 6** you can see the finished cockpit tub including the seat adjustment cord.

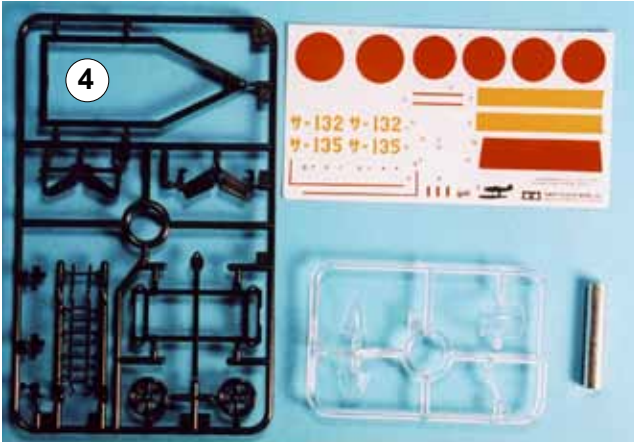

tion of the tubular A frame on part A11. I recall reading many years ago that the Rex had an A Frame and the George had a V frame, or maybe it was the other way around. Regardless, I could not locate that particular piece of information again, so I left the rear bulkhead as is, hoping that mine is

grey pieces (**Photos 2 and 3**) for the basic airframe, 10 black parts for the beaching dolly and 4 clear pieces (**Photo 4**). A modest part count with ample detail seems to be a hallmark of Tamiya kits and the Rex is no exception.

correct.

After this five minute modification was completed, the entire cockpit

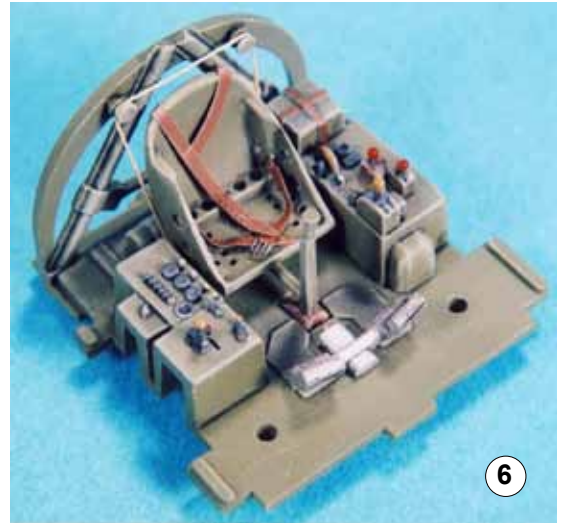

CONSTRUCTION

I started with the 10-piece cockpit and while sounding rather rudimentary it is actually packing a good level of detail. It is only missing one major component; specifically, the two pulleys and rope style cord, which are used to control the seat height. Using my Waldron punch and die set, the pulleys were made from 0.010" and 0.015" disks of styrene and glued in place on part A11 rear bulkhead. The positioning of these pulleys is shown in **Photo 5**. One thing I could not confirm was the orienta-

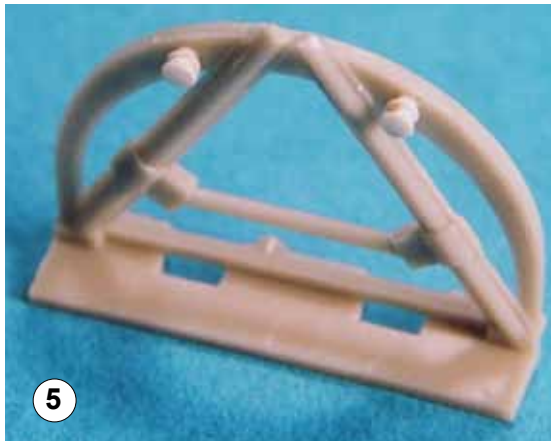

Part A18 is the instrument panel and cowl guns. The lower tubular framework was painted X261, while the instrument panel itself was airbrushed with Testors Black Chrome. After some light grey dry brushing, Mike Grant instrument decals were added. The two 7.7mm cowl guns were finished in the Testors Gunmetal, which has a blue colour and not the more commonly seen dark metallic grey. **Photo 7** provides a view of the completed instrument panel.

The Mitsubishi Kasei engine was first airbrushed silver, given a black India Ink wash and detailed with

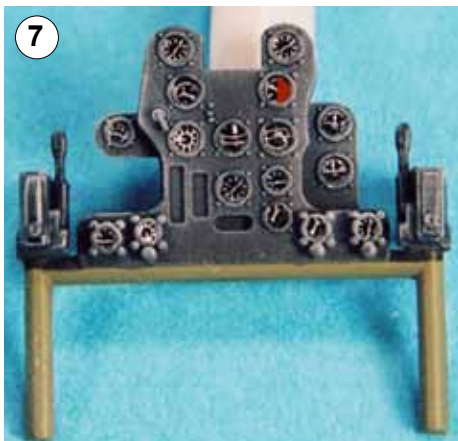

121 from the 22nd Special Base Force in early 1945 at Balikpapan, Borneo. It has blue and white tail codes, the yellow leading edge wing bands are overpainted in green and it has no headrest/rollover structure. Problem is, nobody makes the blue and white codes in 1/48. So, I asked a friend if he could produce these markings on his ALPS printer. He told me it would not be a problem, but it would take a few months. As I was not in a hurry, I agreed and promptly proceeded to cut off the pilot's headrest from my kit in anticipation of the markings.

ignition leads made from fine solder. In the grand scheme of things it was a waste of time as the completed engine is all but invisible once the fuselage halves are assembled the spinner installed. Oh well, at least I know it's there...

Once you assemble the two wing tops and the bottom piece, construction of the airframe is quick and trouble free. The most important thing to keep in mind is to test fit the wing to the fuselage and watch the alignment before you apply any cement. It is easy to get the wing to sit askew if not properly seated. Once the tailplanes and cowl ring go on you have the option to paint the airframe separate from the main float, or you can do as I did and install the central float before painting. While painting without the float installed, greatly simplifies the process, as it is easier to work the airbrush around the model, it also creates the problem of fastening the central float without marring any surrounding paint.

On the topic of the central float, it is composed of four parts plus a metal weight. Don't forget to install the weight, or else your model will not sit properly on the beaching dolly. The only area of the float that required any extra attention related to the installation of part A8, which is the V shaped front support, as it does not mate very well to the float and involved a few applications of putty blend it into the float.

 **COLOUR SCHEME**

When it comes to choosing a paint scheme for the Rex, unless you are building a prototype, your choices are limited to green over grey. The only area where you have any discretion in colours relates to the tail codes. Every 1/48 Rex I have seen built has either the white 'Otsu 103' markings from Lake Biwa, or one of the yellow 'Sa 132 or 135' tail codes. I wanted mine to be different and I really liked 022

The rear decking behind the pilot was painted X261 (Photo 8) and then both the windscreen and rear canopy section were

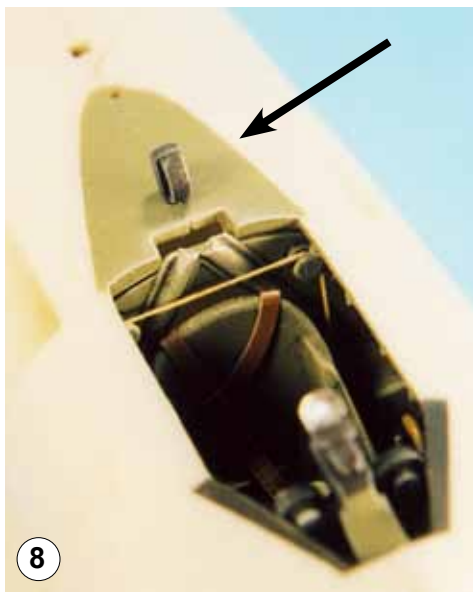

glued in place. I removed the kit supplied 20 mm gun barrels, which protruded from the wings as I had planned to replace them with pieces of hypodermic needles. Now the model would sit for a couple

of months while I waited for the custom markings. Sometime later, I got a call from my friend advising that he would not be able to come up with the blue and white codes, as his printer had crapped out. So, now I am stuck with a Rex that is minus one headrest, which eliminates me from building any of the three options provided in the kit. So after a lengthy search of my references, I came up with one option, namely Sa 951 07 from the 951st Kokutai. From what I can tell in the photos of this unit's Kyofus, this particular airframe may not have been fitted with the headrest. As I had Letraset dry transfer lettering which matched the font used for the tail codes on the Rex, I decided to paint all the markings on this model.

 **PAINTING**

So with scheme in hand I proceeded to paint the wing leading edge bands and the area of the vertical fin where the Sa 951 07 codes would be using Xtracolor X11 RAF Trainer Yellow. This yellow is a little darker than the often used U.S. Insignia Yellow and I feel is a better match to the Japanese yellow. Xtracolor X103 Insignia Red FS 11136 was airbrushed where the hinomarus, wing walks, and warning bands were located and all these painted areas are shown in Photo 9. Subsequent to the time this photo was taken, I also painted the thin red and white bands which identify the location of the beaching dolly. The only decals used on this entire model were the instrument dials.

In Photo 10 you can see where I have applied the Letraset dry transfer lettering where the tail codes should be. After the camouflage colours are applied, the black Letraset lettering is lifted off using some masking tape. The trick when using this method is not to burnish down the dry





transfer lettering to the model. Pressing it down with your fingers should be sufficient to seal the edges and prevent paint from bleeding under the lettering. If you burnish down the lettering too much, it will be too difficult to lift off later on.

Next in **Photo 11** you can see where I masked the fuselage hinomaru and then airbrushed some Xtracolor X775 Olivgrun to represent the overpainted white ring to the hinomaru. After the green dried, I cut a ring of masking tape to what would have been the size of the white ring and applied it around the previously masked hinomaru (**Photo 12**). This ring of tape will stay in place until all subsequent painting has been completed.

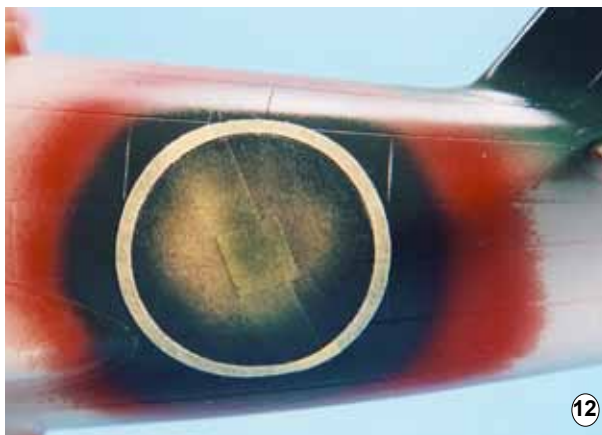
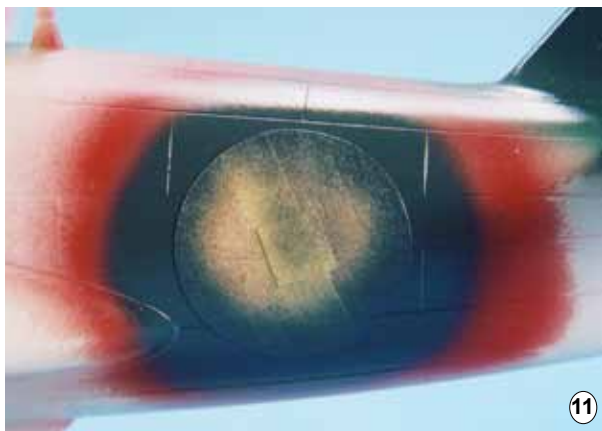

For the camouflage colours I used Xtracolor X134 Grey FS 16307 which, according to information published on the J.aircraft.com web site, is the generally accepted undersurface colour. This supposition is supported by individuals who have matched the FS595 Fan Deck with protected areas of paint on one of the Rex's on display. The upper-surface colour was more difficult to match for, depending on which reference you choose to follow, it could have been anywhere in the FS range of 34108, 34092, 34059, or even 34077. You will hear terminology

thrown around such as Mitsubishi Green, Nakajima Green and Kawanishi Green, which is somewhat misleading.

JAPANESE CAMOUFLAGE

During 1938, the Imperial Japanese Naval Aeronautics Headquarters issued a paint standard that was intended to standardize the colours applied to naval aircraft. This document was called Temporary Specification No.117 Additional Volume. All manufacturers were supposed to be using this standard, which implies that all manufacturers should be using the same green, but in reality they did not. Whether these variances were due to material shortages, multiple suppliers or possible errors in specific paint batch formulations is yet to be determined. But to say that Kawanishi Green is a certain colour and should be applied consistently is erroneous and exhibits two dimensional thinking. The preceding is a précis of my understanding of the camouflage applied to Japanese Naval Aircraft and is what I chose to follow when I painted my Rex.

So after all that, I painted my Rex using a mixture of Xtracolor X114 Medium Green FS 14092 and X353 Japanese Naval Green. I don't recall the mixture ratios because I didn't record them. I just mixed up various batches of paint until I arrived at what I thought was a best possible match to the green found on Kawanishi relics in accordance with the currently available reference information on hand. Is it 100% right? I doubt it, but it looks close enough to me. However, I am

deeply indebted to David Aiken and Ken Glass for all their assistance in demystifying the paints used on Japanese aircraft. In **Photos 13 and 14** you can see the results of this rather exhausting study, as well as the painted markings.

WEATHERING

I mixed up a medium grey wash using Winsor & Newton Ivory Black and Titanium White oil paints and Turpentine, which was flowed into all the panel lines. A slightly darker wash was used for the control surfaces and when all this was dry, I applied some Xtracolor X500 Duraluminum with a 000 brush to represent some paint chipping. I intentionally kept the chipping light, except on the starboard wing root, as photos seem to support my opinion that these aircraft were not as heavily weathered as some of the other JNAF aircraft. All this was followed by a few airbrushed coats of Testors Dullcote. Photos 15 and 16 provide two views of the model at this stage. In hindsight, I should have used a little darker wash on the upper surface, as the panel lines seem to have all but disappeared following the application of Dullcote.

Light olive green chalk pastels for the upper side and medium grey pastels for the undersurfaces were sparingly applied to add some subtle weathering to the basic airframe, while a slightly heavier application of brown, slime green and dark grey pastels were applied to the main float to create the impression of a waterline stain, while black pastels were used to add the exhaust staining.

FINAL STEPS

At this point all that remained was to install the propellor and antenna wire and to paint the navigation lights with dark red and dark green gloss enamels. The kit beaching dolly was assembled and airbrushed a very dark grey. This was followed by some light grey dry brushing to highlight the details and trace amounts of rust coloured pastels were applied around some of the bolts and reinforcing plates to depict some use. The completed model was glued to the dolly, which is a departure from my normal practice, but considered necessary as the dolly has a tendency to scuff the finish on the float. I knew well this scuffing would only get worse the first time the model is entered in a contest, due to the handling by some myopic, hamfisted judge who feels it's his God given right to fondle every model on the table.



 REFERENCES

- ◆ *Kawanishi N1K Kyofu/ 'Rex' & Shiden/ 'George'*, Profile No. 213; Profile Publications, London, England.
- ◆ *Kawanishi N1K1/N1K2 J*, Model Art No. 304; Model Art Company Ltd., Tokyo Japan.
- ◆ *Camouflage and Markings of the Imperial Japanese Navy Fighters in WWII*, Model Art No. 272; Model Art Company Ltd., Tokyo, Japan.
- ◆ *Japanese Information International*, Asahi Journal, Vol. 2, No. 4
- ◆ *Japanese Military Aircraft Illustrated, Vol. 1 Fighters*, Koku Fan Illustrated Special; Bunrin Do Co. Ltd, Tokyo, Japan



- ◆ *Kyofu, Shiden, Shidenkai*, Famous Airplanes of the World No. 53
- ◆ *Japanese Aircraft Interiors 1940 1945*, Monogram Aviation Publications



About the author:



Randy Lutz was born in Kingston and raised in the Ottawa area. He has been employed for 33 years by the Federal Government. Modelling since childhood, with a few breaks along the way, his main area of interest is 1/48 WWII aircraft, with strong emphasis on small air force and foreign markings. Randy has been a member of IPMS Canada since the early 1990s and a member of the National Executive since 1996.



The LEGEND 1/35 CENTURION V becomes an 'Agony Wagon'-a 1970 Canadian Army 'Cent'

By Gary Barling, C #0014

IPMS
Ottawa



BACKGROUND

"The Korean War [1950-1953] had served to highlight the need for a new tank to equip the Canadian armoured units both in Germany and at home in Canada. Fortunately, the government and military had a chance to see a reasonably new tank that had made quite an impression on its users – and the enemy. That tank was the British Centurion Mark 3. The Centurion's well-sloped armour, superior mobility and its excellent gun and fire control systems proved to be a real winner in Korea, and far superior to the then-troubled US Patton series. So it was that, in 1952 and 1953, the Canadian Army took delivery of 274 Centurion Mark 3 tanks, contrary to the policy of procuring North American types for vehicle equipment."

In 1968 I took my initial armour officer training on Centurion Mark 5's at the Meaford Tank Range near Owen Sound, Ontario. Upon posting to the 8th Canadian Hussars (Princess Louise's) at Canadian Forces Base Petawawa, I found the Regiment partially equipped with the same type of tanks. These carried a three-colour camouflage scheme of olive drab, green, and sand. I decided to build this model as one of the tanks from that era.

Oh, yes: 'Agony Wagon'? That's the nickname these tanks had in our service. Why? If you ever tried lifting one of the road wheels, or changing the massively heavy track, or taking a day and a half just to change the spark plugs, you would soon appreciate the nickname!

THE KIT

The Legend Centurion is an impressive kit, featuring well-cast cream-coloured resin, photo etch, wire and cording. The instructions come in the form of a two-sided sheet of colour photos showing numbered parts and larger assemblies, which show where the parts are to be placed. Incidentally, the red marks on this photo (**below**) are my way of keeping track of which parts have been fitted where. The kit is still available but, at a price of \$175.00,

Overview & Summary
Subject: Legend Centurion Mark V
Kit #: LF1092
Scale: 1/35
Contents: Resin parts, Photo-etch, wire, cord, no decals, photo instructions only.
MSRP: CAD \$175.00

and now in competition with the AFV Club Centurion offerings, I suspect that it will not be on the market for much longer.

I broke the construction and finishing of this

An example of the parts layout for the kit.

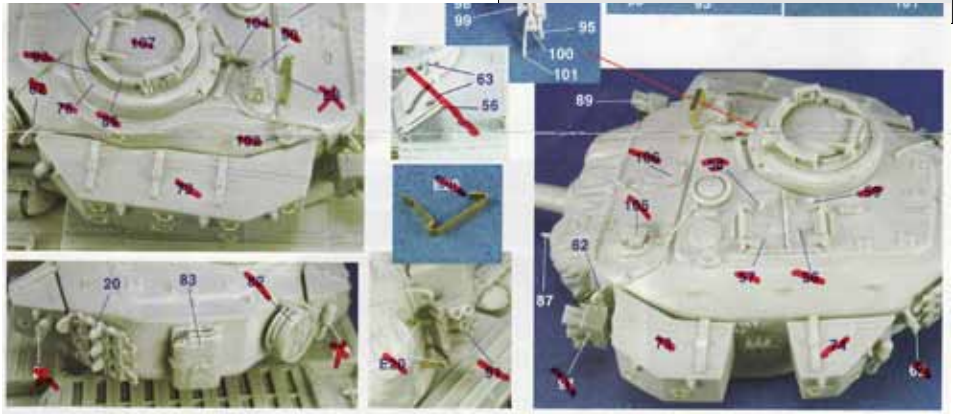

kit into several subassemblies and stages. These were: the turret, hull, suspension, paint scheme, and final finishing. I'll discuss each in the same order. **"Driver, Advance!"**

THE TURRET

The turret comes a one solid central part, onto which a large number of parts, both resin and photo etch, are fitted. The overall quality is very good, although there are a few areas that need modification or additions. These include:

- removing the large ID numbers cast onto the front of the turret (**N204**), and the strange 'O' that appears on the canvas mantlet cover;
- adding signal wire to the spool fitted onto the back of the turret, just to the rear of the crew commander's cupola;
- adding the wire tie-down points on the turret and other areas (also known as 'footman loops'); and
- replacing the gun barrel.

I used a Dremel and then sandpaper to clear off the noted unwanted turret details. The 'sigs' wire was thin plastic coated wire used to connect field telephones into the turret. I used EZ Line, but any thin shiny black material will do. The turret tie-downs are only partly moulded: only the portion that is actually welded to the tank's surface is there. Modellers must drill a small hole on the 'inside' edges of each weld set, then fit a small piece of wire into the holes to replicate the tie-down. Not difficult, just a smidge tedious. And finally, the Hussar tanks carried the early 20-pounder gun without the fume extractor part way down the barrel, but the kit provides only the later version with the extractor. The Barrel Store provided a beautiful turned-aluminum barrel from Barrel Depot: BD35021, 20-pounder for Centurion Mk. 3. Even the rifling can be seen! And don't

worry about the Mk. 3 designation: this is the one we had on our unit Centurions.

The remainder of the detail parts fit very well. As an aside, the stowage bins on either side of the turret feature a pronounced gap between them and the turret sides. These were bolted into place on the real vehicle, and you can see clearly down through the gap: ask me how I know! Note that the external fire extinguishers fitted to the rear of the bins were not carried on our Centurions. As well, a grab handle was fitted to the crew commander's hatch using



Turret rear, showing telephone cable reel and footman loops. Paint details have yet to be added.

Turret with new gun barrel and other details fitted out. Initial paint work has been applied.



(again) the drilled hole and wire technique.

I covered the mantlet with tissue paper, lightly dampened to hold its shape and then brushed it with thin white glue. This represents the canvas cover fitted to prevent leaks and other weather-related oddities from entering the turret. I used a thicker piece of wire to represent the lifting lug just behind the mantlet. The PE smoke grenade framing was a slight challenge to bend and fit, but not overly so. It certainly looks right! I replaced the water can with a spare plastic version, and the spare trackpads with extras from my replacement tracks (of which more below).

THE HULL

THE HULL

The hull is a one-piece moulding, hollowed from underneath. The only challenge I encountered was sawing off the large excess resin "plate" attached to the front of the part. Once removed and the sawn edge cleaned up (a bit of sanding was the only requirement), continued construction was straightforward. There are many parts, both resin and PE, that are to be fitted to the hull, but the work is not difficult if you keep track of what went where on the instruction sheet (I highlighted the parts in red, as noted). The key here is patience! I suppose that the most frustrating part for the general public is the fact that parts are not named: just put part 39 here and part 60 there, and move on. It might be interesting to know that this bin held the driver's wet weather hood, or that assembly clamped the gun securely while on road moves, or these rubber pads protected the gun from bouncing off the rear deck in full stabilization. No names, no paint callouts... research will be required for this baby!

The one part assembly that is weak is the tow cable. Legend provides a few resin fittings and copper wire to fabricate the cable with cord, but the cord itself does not look

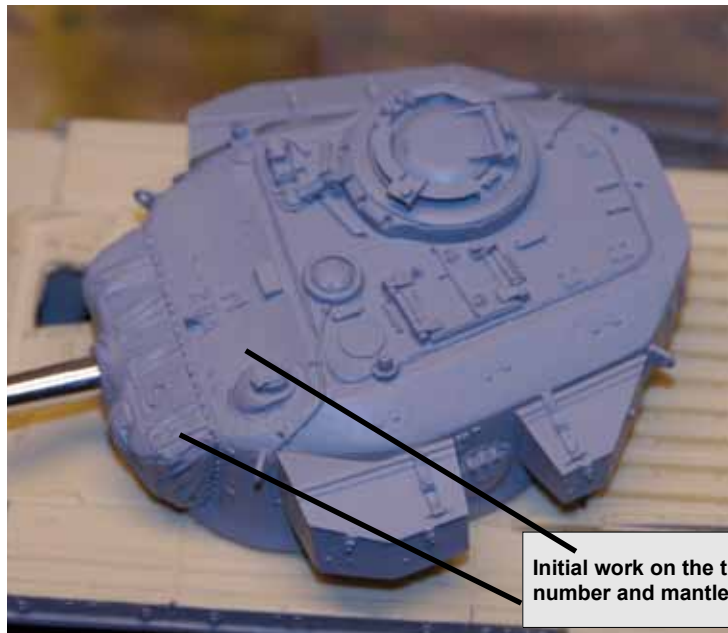

Initial work on the turret, with turret number and mantlet "O" to be removed.



The one-piece hull with early details fitted to rear. The suspension has also been started.

use an aftermarket set of AFV Club Centurion hard plastic track links rather than the resin sections offered in the kit. The main area of concern, however, was the final "sit"

outer wheel made it easy to separate them and clean them up with a bit of sandpaper. At this point, all was in place and ready for the tracks.

And then the next problem hit. The Tamiya sprockets did not quite fit the aftermarket tracks. Almost, but not quite. Fortunately, I am a highly skilled and outrageously expensive surgeon, so it was no real problem to carefully snip off a couple of sprocket teeth, fit the tracks around those that remained on the sprocket, and then reattach the teeth through the openings in the track itself.

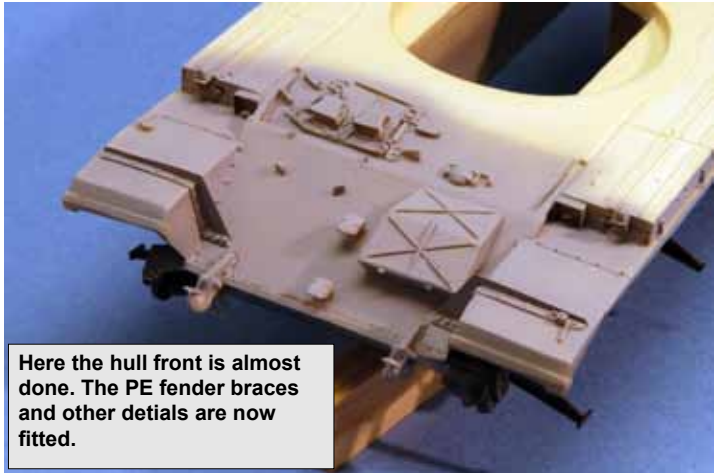

Here the hull front is almost done. The PE fender braces and other details are now fitted.

of the model. Add to the mix the fact that I, with over half a century of experience, made the most obvious of errors, and you can imagine my frustration level... mostly with me!

First, the suspension units. Again, I fitted these to the hull in accordance with the pictorial directions, and with no problems encountered. The front idlers went on without a whimper.

And it was around this time that I made the "most obvious of errors." The steel sideskirts on the Centurion are attached to the fenders along the top, and are held in place by three reinforced braces, which are attached to the hull between the suspension units. No problem: fit them in place and move on. Except, in a mind-boggling hiccup, I attached them...*upside down!* By the time I realized my error, the CA glue had well and truly set. In my defence, I must say that the braces extended too far out from the hull sides, and so could not be used without major shortening. I decided to trim them right back as far as I could, fit the sideskirts to the upper fenders (as called for in the instructions), and back the skirts at their joining ends with a bit of tape. Suspension units and hull sides were painted in the Olive Drab mix described below before fitting the sideskirts. The wheels, of course, were painted their respective colours before fitting to the suspension units.

anything like the real thing. I found the Eureka XXI series of tow cables at CAPCON 2009 in Ottawa, and noted that the set for the Merkava Mk. II was a very close match to the Centurion cable. With a little surgery, a passable example was manufactured, and fitted into place with minimal trouble.

However, the rear drive sprockets were a totally different affair. These came encased in a virtually solid block of resin. I got one of them free after much sawing, chiseling and grinding, but the other three were just too solidly embedded. However, there was a ray of light coming from my storage room: an old Tamiya Centurion 3 kit called out and offered her sprockets for the Cause! Wonderful, says I, and in no time they were shimmed and glued into place, lining up with the previously attached suspension units. The road wheels were themselves well attached to their casting blocks, but the smooth surface of the

With all of the suspension done and while fitting the sideskirts, I came across what might be an error in the kit, but which may also be an error with me. I found that, with all assembled, the model tended to display a slight "nose down" attitude. Nothing overly serious, but (if you'll pardon the observation) having been around these vehicles at one time, it was noticeable to me. I can't recall fitting anything incorrectly (notwithstanding the sideskirt braces!), so the fault might be resident in the kit. Then again, I am anything but perfect...

THE SUSPENSION

I kept discussion of the suspension as a separate topic, for it was here that I encountered my highest level of frustration. And I must say directly that part of the frustration was my own doing. I decided to

The suspension moves along. Initial paint on the hull, and turret and mantlet details removed as discussed.



PAINT SCHEME

Having conducted my training at Meaford in overall Olive Drab Centurions, I was quite surprised to see the three-colour cam schemes worn by the Hussar vehicles. So much so, in fact, that I subsequently clambered all over one of them and came up with a three-view drawing that I submitted to RT...back in 1969! Fortunately the drawing survives, and is reproduced here as the guide to the particular vehicle that I modelled: **CFR 52-81142**. For those who may not know, 'CFR' is the Canadian Forces Registration: '52' is the year in which the vehicle came on strength, '81' (or whatever the next two digits are that follow the 'dash') is the coding for the specific type of vehicle (in this case, of course, it refers to Centurion gun tanks), and

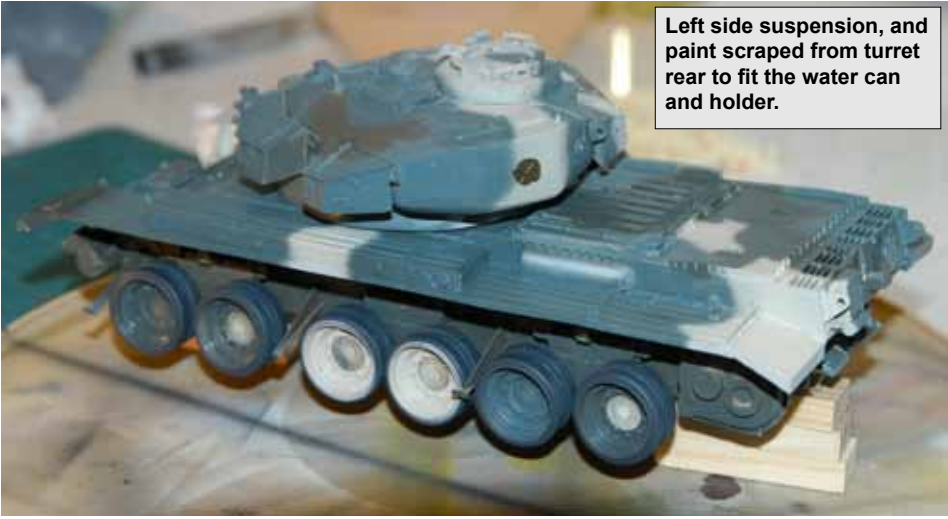

Left side suspension, and paint scraped from turret rear to fit the water can and holder.

a touch of Medium Grey or White. The OD should tend to brown rather than green.

Medium Green = 10 x drops X353 (Japanese WW2 Navy Green...really!), plus 4 x drops of X141 (White).

Sand = 10 drops X105 (Sand), 2 drops X10 (Matte Interior Grey Green), plus a trace of X103 (Insignia Red) or X242 (German WW1 Topside Purple).

Having primed the surface with Mr. Surfacer, it was a more or less simple matter to freehand the cam scheme using the three-view drawings as a guide. I extrapolated the scheme on the right side and lower glacis from the drawings, and from a good photo of the right side of what I'm pretty sure is 52-81142. Xtracolor Tyre Black was used for the bumper pads on the rear deck, fitted to protect the fire control system from the effects of slamming the barrel down on solid metal while in full stabilization.

Markings were pretty spartan. "142" carried the squadron tactical sign on either side ("B" Squadron – a black square), plus the serial number on both sides of the turret and on the rear right side of the hull. A black and white striped radiator air deflector was carried at the rear.

FINISHING

The balance of the finishing was straightforward. I used a light wash in recesses and around items such as the hatches, vision blocks and other features. I airbrushed a very thin mix of brown and black (roughly eight parts thinner to one part paint) to add a bit of depth to the model. Weathering (including paint chipping, wear and fading) was courtesy of the Tamiya Weathering Master sets.

Antennas on the real tank were made up of two brass tubes that fitted together. This assembly, in turn, fitted into a thumbscrew-tightening assembly, which was then slipped into the antenna bases provided with the kit. I fashioned the antenna from thin brass wire, and added a slightly widened area about halfway down to replicate the join. This was a dark green colour, as I recall: any green darker than that used in the cam pattern will do nicely.

CONCLUSION

For the most part, this was quite an enjoyable build for me. I was happy to try out a full-fledged resin kit, and the opportunity to do so AND build a Regimental Centurion was a real bonus.

"Driver, Halt!"
"Switch off!"
"Crews front!"



Starting to come together: side skirts, squadron tac sign, spare track holder (strip) and some detail painting.



Almost finished.

'142' refers to the vehicle itself. Hence, 52-81142 is the 142nd Centurion tank brought on strength in 1952. As an aside, those who know me know that I lost the tips of three fingers on my right hand during my military service. Well, the vehicle that did the deed was 52-81060: yup, my souvenir of service on Cents. I've always hoped that '060' ended up as 40,000 razor blades!!

involved are Olive Drab, Medium Green and Sand. This is all well and good, but the specific colours are not readily available. Accordingly, out came the paint mixing tools. Now, I am particularly fond of Xtracolor paint for more reasons that we can discuss here. All to say that I used my stocks to come up with suitable mixes for this cam scheme. Here they are:

Back to the paint scheme. The three colours

Olive Drab = X112, slightly lightened with



REFERENCES





- ◆ Don Dingwall, The Centurion in Canadian Service, Service Publications, Ottawa, Ontario, August 2005.
- ◆ Barry Beldam, Canadian Centurion Gun Tanks, Canadian Armour Series, Volume 1, Kingston, Ontario, November 2003.
- ◆ Michael Norman, Centurion 5, Armour in Profile Series, Number 23, Profile Publications, Great Brookham, England, 1967

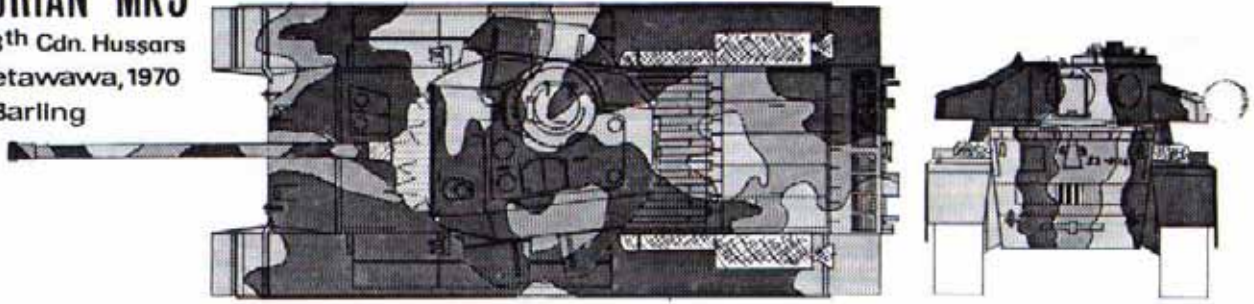

4
CENTURIAN MK5
'B' Sqn, 8th Cdn. Hussars
CFB Petawawa, 1970
by G. Barling



Serial 52-81142 in white on each side of turret. Centered on right side; forward of pistol port on left side. Also on hull rear.

-  Green (Humbrol AFV green)
-  Olive Drab (Humbrol OD)
-  Sand (Humbrol uniform khaki drill)
-  Khaki (mid-brown...mantlet cover)
-  Rust (deep brown)

Bare metal area

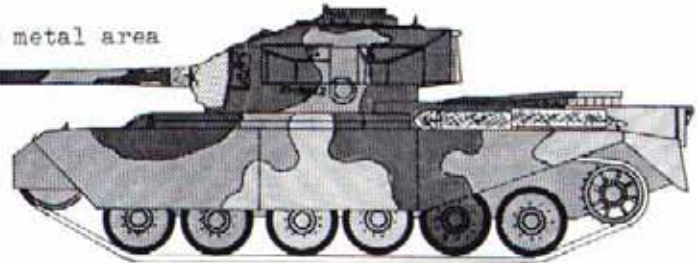

NOT TO SCALE - For Centurian Mk.5 details see old profile series #23

Hull & suspension units under side skirts are Olive Drab



(Above) The cam pattern from RT circa 1970. (*Spelling mistake of 'Centurion' name was an editorial error of the time*)

(Left) A Centurian Mk. 5 from the 8th Hussars, in the fall of 1969.

◆ My six months 'up close and personal' with the Centurion V.

(Endnotes)

¹ Don Dingwall, The Centurion in Canadian Service, Service Publications, Ottawa, Ontario, August 2005, pp. 3.

AFTERMARKET PRODUCTS

◆ Aftermarket barrel, tracks and tow cables from the Barrel Store:
www.thebarrelstore.com

SPECIAL THANKS

◆ Janet Lacroix, National Defence Imagery Library, CF Joint Imagery Centre, through Master Warrant Officer (Retired) Steve Sauvé, for the colour photos of the last mobile Centurion 5 at Petawawa, 1977.

◆ Barry Beldam, an exceptional modeller in 1/76 scale, for the loan of his extensive photo files on the Centurion. Visit his website:
www.armouredacorn.com



About the author:

Gary Barling was born and raised in the Toronto area and subsequently served 40 years in the Canadian Army. He's 64 and has been retired since 2004. Modelling since 1955, his main area of interest is aircraft, with strong minors in armour and ships. Gary's been a member of IPMS Canada since 1965 and currently the Chapter Liaison Representative on the IPMS Canada National Executive. He maintains dual citizenship in both IPMS Ottawa and IPMS Farnborough, England.





THE 'BONNIE'

CREATING HMCS BONAVENTURE FROM THE HELLER 1/400 HMS COLOSSUS KIT

by Ryan Cameron,
C#6026
Langley, BC



BACKGROUND

HMCS Bonaventure was a Majestic class aircraft carrier, originally laid down for the British Royal Navy as HMS Powerful. She served in the Royal Canadian Navy and Canadian Forces Maritime Command from 1957 to 1970 and was the last aircraft carrier to serve Canada. Bonaventure was commissioned into the Canadian Navy on 17 January 1957, upon completion of its refit and modernization. The Navy's new flagship, affectionately known as the "Bonnie", originally carried a force of about 34 McDonnell Douglas F2H-3 Banshee jet fighters (out of service 1961), Grumman CS2F Tracker ASW aircraft (built by de Havilland in Toronto), Sikorsky HO4S helicopters and, in 1964, new CHSS-2 Sea King helicopters were added to Bonaventure's complement. During 1967-68, she underwent an extensive refit to see her through the latter half of her service life; however, she was paid off just two years later and sold for scrap.

THE KIT

This Bonnie build started about two years ago when Heller re-released their Colossus kit. I bought a couple of the kits with the idea to build the HMCS Magnificent and the Bonnie. They sat on the shelf while references, parts and such were being made available. Finding the Trackers

by L'Arsenal was the first step and with WEM releasing the Colossus photo-etch, it seems I had everything I needed. An article in an old 1997 Plastic Shipmodeller by Ray D. Bean gave me some good ideas on what I was about to build and looking at the parts; I ended using only three of the kit parts, which were the hull halves and the deck (**Photo 1**). The rest was going to be scratch built.

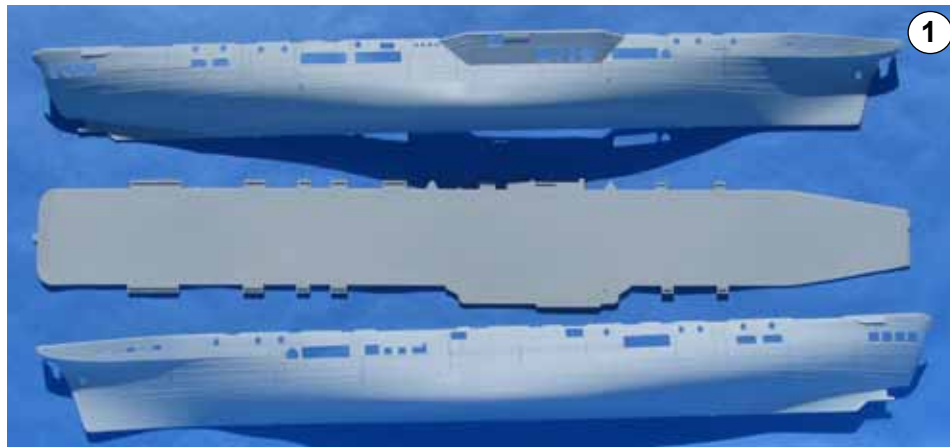

THE BUILD - FIRST STEPS

The first thing to do was sand all the raised detail and fair in all the openings that were not pertinent to the Bonnie; I used styrene as a back plate and putty to fill in. New openings were made and along with the rest of the existing openings, were boxed in from behind making sure they were in solid as I did not want any of them popping loose during construction and not being able fix it once the deck was on. The 3"/50 gun sponsons were going to be tricky, as I needed four of them. Using Ray Bean's method from the old Plastic Shipmodeller article, (**Photo 2**) I managed to get them done with little trouble. I just have to mention the Tamiya Polyester two part putty (yellow stuff) here, as I used a ton of

3a

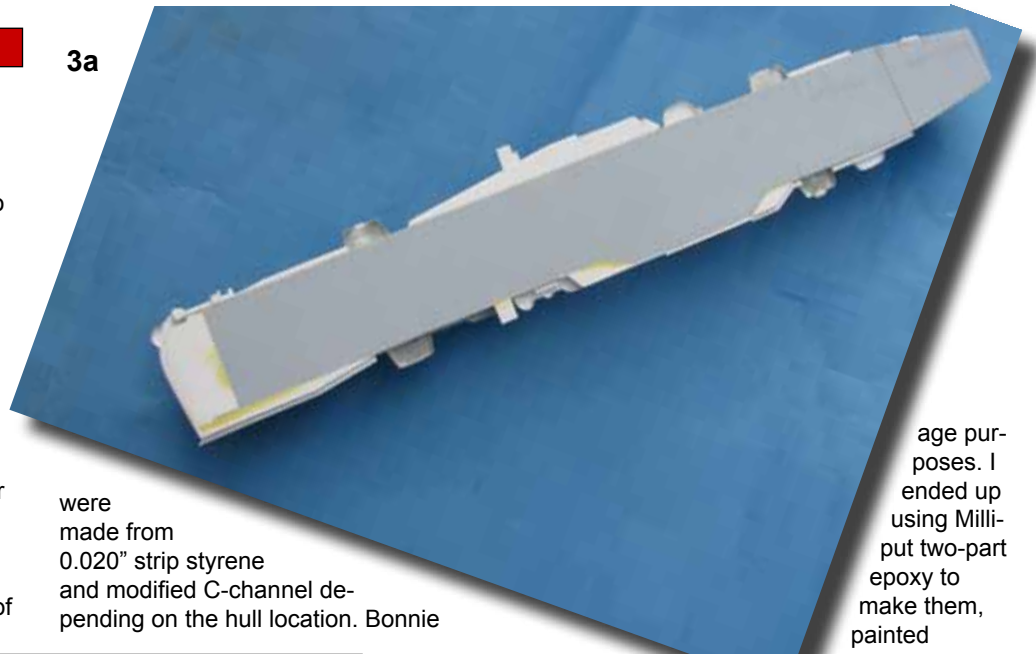

were made from 0.020" strip styrene and modified C-channel depending on the hull location. Bonnie

age purposes. I ended up using Milliput two-part epoxy to make them, painted

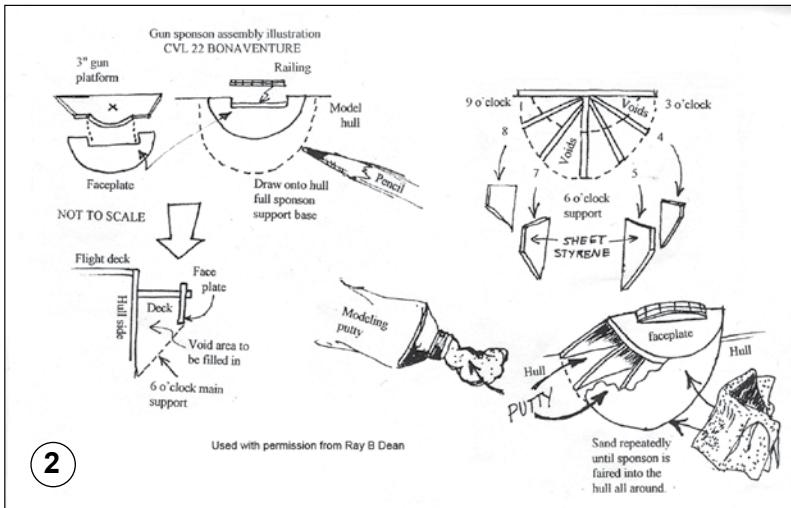

it for the first time on the sponsons and it was fantastic, easy to work with and sanded beautifully. The Bonnie's 3"/50's were made from a mixed bag of spare resin parts and brass from the spares box and using a 1/350 Veterans Models 3"/50 that I use for my other RCN projects as a template.

All the various platforms were built using the plans and reducing them to 1/400, cutting out the shapes and tracing them onto various thickness of sheet styrene. With the deck in place, I added sheet styrene to the aft and midship portions to create the angle deck that was a major feature of the modified Majestics. I was happy with the look but a little disappointed that I did not have enough curve on the aft portion of the deck. I scribed the catapult launch area and aircraft elevators using the plans as a template (**Photos 3a,b,c**). Walkways

had perforated railings along the catwalk and I used some brass sheet from a great local train store that looked good and bent easy for all the angles and corners. Details were next added to the platforms and walkways using WEM and L'Asenal PE reels, ladders, doors and styrene for bits and boxes, anything to make it look busy. The ships boats and dinghies supplied in the kit were OK, but I had a great set of extras from Resin Shipyard's HMCS Haida kit. Even though these were in 1/350, the size difference was negligible to the kit supplied boats and looked better compared to photos of the real thing. Next up was trying to figure out how to make the life rafts located on the forward starboard platform and portside aft. Based on photos that I had, they looked liked they were wrapped in some kind of canvas for stor-

and detailed with foil straps, looked pretty good.

Now it was time for the Bonnie's superstructure, which was going to have to be built from scratch. Working from the plans, I made templates for each level from 0.040" sheet and wrapped each level with 0.010" using plenty of CA glue. The bridge wings were added next using styrene sheet and some spare resin pieces from the spares. The windows were from the WEM Colossus sheet and modified for the



SPS 10 Radar on the main mast came from the spare Haida set and again, even though it is for 1/350, it was the only game in town and the size difference was minimal. The next mast that carried the SPS 12 Air Search radar came from a spare WEM set. I added a small platform

Bonnie. Sharp eyes will notice in the photo that I have glued the funnel on backwards and I didn't notice until after the picture was taken (Photo 4). Lockers and such were added before moving on to the radar masts. Having a good source of reference pictures to work from really helped in this area.

using 0.010" strips cut to shape and the radar itself came from a combination of a 1/400 French Radar set from L'Arsenal and spare Haida parts. Now, last, but not least, was the SPS 8 Range Height Finder. This was going to be tricky as there is nothing close available. Using the L'Arsenal French radar set, I managed to cobble together something that looks like an SPS 8 to my eyes. After painting and detailing with ladders, they were set aside in order to paint the hull. (Photo 5).

Red, masked that, and followed it up with the WEM Shipline Grey. The deck green was made using the colour chart at the Resin Shipyard website with a mix of 5 parts MM Russian Interior Blue Green to 1 part Testors matt Beret Green. Apparently, this colour is similar to what the RN used and is available from WEM. MM Euro Grey 1 was a good match for the bare decks found on the super structure and openings showing bare deck on the lower hull. The grey used for the landing strip was an unknown mix, just looked right from the colour photos available. A few coats of Future sealed the hull and it was ready for decals. The deck markings were a mix of paint (yellow lines) and the fantastic complete decal set from CanMilAir. After sealing the deck with Future again, I gave the hull a light wash of thinned Raw Umber/Black to add a little depth and bring out the details. To finish it off, I gave the hull and superstructure a coat of Poly Scale Flat.

PHOTO-ETCH DETAILS

As there was no dedicated PE mast for a Bonnie, I had to look around at what might work. I went online and found WEM made a sheet for the old 1/415 Frog HMS Tiger that looked like it suited my purpose. I ended up soldering the bottom half of the Tiger mast to the top half of a spare mast from a WEM destroyer set, giving me something very close to what I needed. The rest of the mast came from WEM's Colossus, Tiger and spare PE. The

BONNIE'S AIR WING

So now it came time for the eight resin Trackers from L'Arsenal and are little gems with fine PE options. The Sea King came from the spares that was intended for 1/350, but measured closer to 1/400 upon closer inspection. One of the pictures I had showed a nice display on the deck and decided this is how I would display them. I gave the Trackers and Sea King a wash in warm soapy water and gave them a quick blast of Floquil Primer from the can. I airbrushed a coat of Medium Sea Grey and hand brushed the Extra Dark Sea Grey. Making more punishment for myself, I cut off the wings of seven Trackers and placed them in the folded position. CanMilAir once again came to my help with a request to do the Bonnie air wing as seen in late 1964; I really wanted to show the White Ensign on the rudder. Bill did a fantastic job with the artwork and over a few rainy nights the decals really brought the Trackers to life. I still have nightmares about all those small decals. One thing that did make my life easier was buying a Waldron punch & die set last summer and I punched all the roundels out of the sheet, quick and clean. The Sea King was given a blast of white to act as a base for the Day-Glo nose and tail stripe, then given the same treatment as the Trackers. The PE landing gear and doors for the Trackers were next applied in holes I had pre-drilled and once installed I found the main gear pretty fragile. I ended up cutting some fine brass wire to help reinforce the gear, and I glued on the resin wheels. Once painted, they look okay. A

COLOUR SCHEME & PAINTING

Canadian ships have a very unique colour that is now available from WEM and sold exclusively from the Resin Shipyard. After a coat of primer, I sprayed the black bootline stripe and masked with Tamiya tape. Next, I sprayed the bottom with WEM Hull



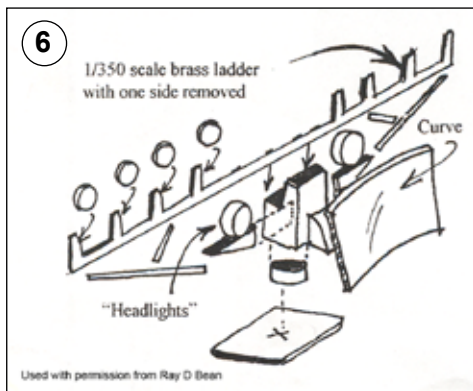

quick blast of Poly Scale semi gloss on the aircraft gave them a bit of sheen, but not too glossy. My method for painting the canopies was giving them a basecoat of silver and once dry, a top coat of Tamiya Smoke.

With the aircraft done, it was time to add the small details like railings, aerials and the mirror landing aids x 2. These were made based on a couple of good photos I had, plus another one of Ray Bean's ideas from the PSM article. To make these look the same, I built them both at the same time to keep things consistent. The punch set paid for itself when I built these. Shiplside Grey was sprayed and details to the lights were done with clear green, MM Turn Signal Amber and MM Chrome Silver for the mirror. (Photo 6) All the railings were used from the WEM Colossus sheet and pre-painted prior to attaching to the hull. I attached the superstructure at this point, as I didn't want to knock it during construction. The same thing applied to the folding deck edge antennas that were

WEM items and all the whip aerials made from guitar 'E' strings. I only managed to knock off one whip aerial into the great unknown and had a few extra parts ready for this problem. The ship's main boat crane was dressed up with WEM parts and a few extras such as pulley wheels using the punch set and some PE cables were next added, the whole thing painted, and placed in its proper location on the deck. I decided I needed to add a few extras on the deck to add a little extra colour with the addition of a couple of deck tractors and a wheeled fire extinguisher. The aircraft were now placed in their positions and there you have it, a 1/400 scale HMCS Bonaventure.

CONCLUSION

This was a bigger project than anticipated; I walked away from burnout a few times, but persevered and completed her. I have built up a small collection of RCN ships over the years all in 1/350 and I doubt I will see a Bonnie in my scale, so this is the next best thing...an RCN carrier for the cabinet. I guess I am a glutton for punishment, I have most of the parts for a Maggie to be built sometime in the future, all I need is a source for 24 1/400 Sea Furies...anyone?

ACKNOWLEDGEMENTS

I would like to thank a few people that made this project possible. To Bill Burns at CanMilAir, for his decals, photos and customer service. Darren at The Resin Shipyard, the photo collection really

helped. Jacques Durol from L'Arsenal, for all the extras and customer service and Ray D. Bean for allowing me to use his diagrams.

REFERENCES

Photocopy plans of the Bonaventure. I only had the overhead flight deck plan which also included the superstructure levels and Radar masts.

A.H. Snowie, **The "Bonnie"**. It is a nice book and had a few photos that were useful, but it is more of a collection of stories from the men that served on her. It was a good read.

Patrick Martin, **Royal Canadian Navy Aircraft Finish and Markings 1944-1968**; published by the author, 2006. This series is a godsend for Canadian modellers.

A great website that I stumbled across created by the **Shearwater Aviation Museum Foundation**. They have a wonderful photo collection of all things to do with RCN Carriers. Check it out at www.samfoundation.ca/

Postscript...

"It seems the old saying goes that if you build something you really want, one of the model companies will release it once you're done. The Resin Shipyard aquired the Oz Mods Modified Majestic master and will be releasing a Maggie and Bonnie in 1/350 sometime in the next couple of years. Based on their other releases, it should be a real beauty and I'm looking forward to it"



About the author

Ryan Cameron was born in Victoria and raised in Langley BC. He is 40 and happily married to a very understanding wife who 'gets' the hobby; they have two sons, age 11 and 17, who keep him busy with sports. Ryan is a Vancouver firefighter and has been modelling since the age of 10. He used to build everything and anything, but now concentrates on 1/72 RCAF/RCN aircraft, 1/350 RCN ships and messes about with 1/72 Cdn Armour.



THE 'BONNIE'

1/400 model by
Ryan Cameron, Langley, BC

